

# Survey Report

On behalf of

---

for property located

---

performed by

---

\_ 200\_

© 200\_ \_\_\_\_\_

This document cannot be copied without written permission of the surveyor

Copy \_ of \_

Edition \_

Seal

---

If the seal is not embossed, this document is an unauthorized copy and should be presumed to contain alterations.

## Table of Contents

<b>I.</b>	<b>Administrative Information</b>	
	Client	1-1
	Client's Address	1-1
	Client's Telephone Number	1-1
	Parcel Address	1-1
	Tax Reference	1-1
	Type of Survey	1-1
	Standards	1-1
	Date of Survey	1-1
	Location of Survey	1-1
	Party Chief	1-2
	Surveyor	1-2
	Equipment Used	1-2
	Title	1-2
	Gratitude	1-2
	Distribution	1-2
	Contacts	1-2
	Actions Taken	1-3
	NGS Quad Sheet	1-3
	Survey Procedures	1-3
	Adjustment Technique	1-3
	Field Book	1-3
	Basis of Azimuth	1-3
	Distance Datum	1-3
	Declinations	1-3
	Measurement Information	1-4
<b>II.</b>	<b>General Site Information</b>	<b>2-1</b>
	Flood Plain	2-1
	Inchoate Mechanic's Liens	2-1
	Possession of the Residence	2-1
	Utilities	2-1
	Access	2-1
<b>III.</b>	<b>Parcel Information</b>	<b>3-1</b>
	In General	3-1
	Tax Parcel	3-8
<b>IV.</b>	<b>Encumbrances &amp; Restrictions - Location</b>	<b>4-1</b>
	Zoning -	4-1
		4-4
<b>V.</b>	<b>Potential Overlaps and Gaps - Record Information</b>	<b>5-1</b>
		5-6
<b>VI.</b>	<b>Possible Encroachments - Visible</b>	<b>6-1</b>
	Mailboxes	6-1
	Utility Line	6-1

Uncalled for Monuments	6-2
	6-4
<b>VII. Boundaries &amp; Corners</b>	<b>7-1</b>
Corner 1	7-1
Boundary 1-2	7-2
<b>VIII. Revised Description</b>	<b>8-1</b>
<b>Appendices:</b>	
<b>A: Miscellaneous Maps &amp; Documents</b>	
1:	
<b>B: Records Examined</b>	
<b>C: Conveyance Flow Chart</b>	
<b>D: Description Extracts</b>	
<b>E: Measurement Table</b>	
<b>F: Traverse Information</b>	
1: Solar Azimuth Computations	
2: Stationing	
3: Field Measurements	
4: Reduced Measurements	
5: Coordinates & Standard Deviations	
<b>G: Photographs</b>	
<b>H: Correspondence</b>	
1: Sample Letter to Adjoiner	

## I. Administrative Information

**Client :**

**Client's Address :**

**Client's Telephone Number :**

**Parcel Address :**

**Record Owners :**

**Record Reference :**

**Tax Reference :**

**Type of Survey :**

**Standards :** Standard Boundary Survey Condition \_\_\_. The following standards as applied to a Standard Boundary Survey as currently enforced in the State of Maine have been waived by the client:

1.

**Date of Survey :**

**Location of Survey :**

**Party Chief :**

**Surveyor :**

**Equipment Used :** The following Equipment was used during the course of the survey:

1. Topcon GTS-2R (Total Station) serial number #T01608
2. Topcon TL6DE (Theodolite) serial number #A12408
3. Schonstedt Magnetic Locator Model GA-52C
4. Receiver \_
5. Computer \_
6. Data Collector \_

Note: All equipment used in the field has been checked or calibrated within the last three months.

**Title :** No attempt was made to review or come to an opinion on the title or marketability of the title. Any appearance of an opinion on the title is unintentional. This information should be reviewed by another attorney and all title questions should be referred to the attorney supervising the closing or loan documents.

**Gratitude :**

**Distribution :** A copy of this report has been distributed to the following persons:

Copy	Edition	Person

**Contacts :** The following people were contacted to obtain information:

Date	Name	Address	Tele. No.	Subj.

**Actions Taken :**

1. Record search in the \_ County courthouse
2. Field reconnaissance and search
3. Letters sent to adjoining landowners ( )

Tax Parcel	Owner	Address	City, State
_____	_____	_____	_____

4. Field survey ( )
5. Computations ( )
6. Monuments Set ( )
7. Plat and Report of the survey prepared ( )
8. Review of the results ( )

**NGS Quad Sheet :**

**Survey Procedures :**

**Adjustment Technique :**

**Field Book :** HP-48SX Data Collector

**Basis of Azimuth** : Solar Observations

**Distance Datum** : Local Mean

**Declinations** :

Year	Approx. Declination	Magnetic Reference
------	---------------------	--------------------

**Measurement Information** :

Method of Adjustment (if required)	Least Squares	
Angle Uncertainty	+/- 6	seconds
Zenith Angle	10	seconds
Distance Uncertainty	5 ppm +/- 0.015	feet
Standard Deviation - Azimuth Observed	+/- 12	seconds

## II. General Site Information

**Flood Plain** :

**Improvements** :

**Zoning** :

Front:

Side:

Back:

Street Frontage:

Lot Size:

**Inchoate Mechanic's Liens** :

**Possession of the Residence** :

**Utilities** :

**Access** :

## III. Parcel Information

**In General** :

**Tax Parcel** :

**Tax Parcel** :

#### **IV. Encumbrances & Restrictions - Location**

**Zoning :**

**Wetlands :**

**Flood Restriction :**

**Eagle Nests :**

**Easements :**

**Covenants :**

#### **V. Potential Overlaps, Encroachments, and Gaps**

During the course of the survey and search for boundary information, the following possible overlaps, gaps, and ambiguities were noted. In many cases these are caused by vague information, lost or misplaced records, and inadvertent errors in past conveyances and surveys. At this time no survey problems were discovered that would appear to result in the loss or restriction of the reasonable enjoyment of the property and/or residence.

**Mailboxes :**

**Utility Line :**

**Uncalled for Monuments :**

**Area of Use :**

#### **VI. Boundaries & Corners**

**Corner 1 :** The corner was established in \_ and marked by \_ as described in deed book \_, page \_. Subsequent records called for a \_ as cited in deed book \_, page \_. Records for adjoining property called for a \_ as cited in deed book \_, page \_. During the survey a \_ was found with dimensions of \_. A 5/8<sup>th</sup> inch diameter reinforcing bar (three feet long) was set to memorialize the corner location. A cap similar to the following was placed on the reinforcing bar. Trees within one rod of the corner were marked

with two blazes facing the corner monument.

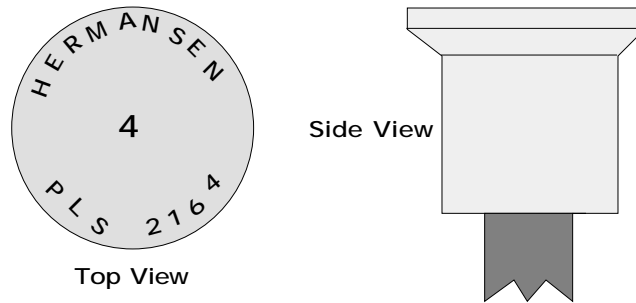

**CAP**

**Boundary 1-2** : The boundary was established in \_ as described in deed book \_, page \_. The historical measurements for the boundary are the following:

Bearing	Distance	Date (approx.)	Source

During the survey a \_ was found on or near the boundary. Trees within one rod of the boundary were marked with two blazes facing the boundary. Trees that are on the boundary are blazed on each side in the direction of the boundary.

**VII. Revised Description**