

**COMMON LOON (*GAVIA IMMER*) BIOGEOGRAPHY AND REPRODUCTIVE  
SUCCESS IN AN ERA OF CLIMATE CHANGE**

By

Allison Byrd

B.A. University of Rhode Island, 2001

A THESIS

Submitted in Partial Fulfillment of the

Requirements for the Degree of

Master of Science

(in Ecology and Environmental Science)

The Graduate School

The University of Maine

May, 2013

Advisory Committee:

Brian Olsen, Assistant Professor of Biology & Ecology, Advisor

Rebecca Holberton, Professor of Biology

David Evers, Executive Director, Biodiversity Research Institute

## THESIS ACCEPTANCE STATEMENT

On behalf of the Graduate Committee for Allison Byrd I affirm that this manuscript is the final and accepted thesis. Signatures of all committee members are on file with the Graduate School at the University of Maine, 42 Stodder Hall, Orono, Maine.

---

Brian Olsen, Assistant Professor of Biology & Ecology

December 3, 2012

## **LIBRARY RIGHTS STATEMENT**

In presenting this thesis in partial fulfillment of the requirements for an advanced degree at The University of Maine, I agree that the Library shall make it freely available for inspection. I further agree that permission for “fair use” copying of this thesis for scholarly purposes may be granted by the Librarian. It is understood that any copying or publication of this thesis for financial gain shall not be allowed without my written permission.

Signature:

Date:

**COMMON LOON (*GAVIA IMMER*) BIOGEOGRAPHY AND REPRODUCTIVE  
SUCCESS IN AN ERA OF CLIMATE CHANGE**

By: Allison Jeanne Byrd

Thesis Advisor: Dr. Brian J. Olsen

An Abstract of the Thesis Presented  
in Partial Fulfillment of the Requirements for the  
Degree of Master of Science  
(in Ecology and Environmental Science)  
May, 2012

Climate change has the potential to shift and restrict ranges for a suite of species. The birds of the boreal ecosystem, like the Common Loon (*Gavia immer*), may be particularly at risk given the changes predicted for this biome. Current range models for this iconic water bird predict that large sections of the United States may lose the loon in the next 100 years, but these models are based on habitat correlations and not the demographic mechanisms that will actually produce the change. The primary goal of our research was to understand the factors that determine loon vulnerability to climatic change at multiple scales. We applied a recursive partitioning technique to analyze loon presence/absence in 288 lakes across the southern edge of their North American distribution using 112 abiotic and landscape-level factors. The resulting binary tree (“decision tree”) classified lakes into groups based on the probability of loon presence, while maximizing homogeneity within the resultant two nodes. The most significant splits in the cross-validated tree were created using lake salinity, acidity, and sulfate levels. We employed similar methods to compare loon occupancy and seasonal fecundity at a smaller scale (New England) to elucidate potential demographic mechanisms of loon persistence. Results from twenty potential predictors suggest that

similar processes are driving loon presence/absence both continentally and within New England (lake salinity, alkalinity, and lake surface area). Loon productivity, on the other hand, was best predicted using the size of the lake and its drainage basin. Lake surface area and characteristics of the drainage basin are thus good predictors of both loon distribution and loon productivity, and are thus also likely to be useful in predicting range shifts in the future. As few (if any) of the predictors of productivity in the best decision trees are likely to change dramatically with climate, these outcomes suggest that future range alteration for loons due to climate change are likely to be more sensitive to annual adult survival (which will influence breeding ground settlement patterns) than environmental factors encountered on the breeding grounds.

After highlighting the environmental factors that predict loon occupancy and productivity, we explored environmental predictors of individual energetic condition. Physiological measures may offer more information about the likelihood of loon persistence, because they can identify covariance between energetic condition and breeding habitat quality. We used blood metabolites and behavioral observations to evaluate the energetic costs of common loons (*Gavia immer*) breeding on lakes across a gradient of environmental, spatial, and social conditions. Using samples collected over two years (n=97) along the species' southern breeding range edge (ME, NH, MA, MT, WA), we identified the number of offspring, daily maximum temperature, and latitude as the most important drivers of the energetic cost of maintaining a breeding territory. Specifically we found that: 1) loons with two chicks expend more energy than those with one, 2) loons near the southern range edge expend more energy to produce a given brood size than those nearer the range center and, 3) birds breeding in warmer temperatures

expend more energy than those in cooler temperatures (controlling for year, territory type, and calendar date, free glycerol levels, size-corrected body mass, and longitude). We suggest that as environmental conditions change in the coming years, blood metabolites offer a promising predictor of population collapse along range boundaries. Energetic condition deteriorated toward the southern range edge and in warmer conditions, controlling for the number of offspring produced, which suggests that loons may be sensitive to increasing global temperatures. We suggest that as environmental conditions change in the coming years, blood metabolites offer a promising predictor of population collapse along range boundaries.

## ACKNOWLEDGEMENTS

I would like to thank the numerous individuals who made this thesis possible. I extend a sincere thank you to my committee members David Evers and Rebecca Holberton for their support. I would also like to thank William Halteman for his statistical expertise and encouragement as I made my way through the world of data analysis. I have countless peers who made project possible including Kate Ruskin, Ellen Robertson, Dave Grunzel, Evan Adams, Leah Culp, Chris Tonra, Adrienne Leppold, James Style, Anna Henry, Laura Kennedy, Anya Rose, Matt Jones, and also Kate Taylor, Carrie Osborne, Carl Anderson, Jeff Fair, Alison Jackson, Ginger and Dan Poleschook, Kristin Ditzler Strock, and Courtney Wigdahl. I cannot sufficiently thank Maureen Correll, Daniel McConville, and Jenny McCabe for their friendship and support during my time at UMaine. I'd like to thank Wren for countless laughs, runs, and canine support. I would like to thank Sue Anderson and Trish Costello for their administrative assistance throughout my time at the University of Maine. My family provided encouragement and love, including Barbara, Ray, Adam Byrd, and Melanie, Dan, Lilly, and Morgan Kerr. Funding was provided by the School for Biology and Ecology, Biodiversity Research Institute, the Maine Agriculture and Forestry Experimental Station, and the Northeast Temperate Network of the National Park Service. Field assistance was provided by Mike Chickering, Tori Polito, Keith Blanchette, Matt O'Neal, Ashley Malinowski, Seth Wile, and Misty Libby. I'd like to thank David Bishop for believing in me and putting me in contact with Brian Olsen, which is how this incredible journey all began

Finally, I would like to extend the most heartfelt thank you possible to my advisor, Brian Olsen. Brian, you have showed me what it means to balance brilliance, encouragement, humor, editing, teaching, motivation, family, exercise, grading, enthusiasm, sarcasm, a seven-plus member lab, confidence, humility, and constant learning... all without losing your mind. I cannot adequately express how much I have learned from you during my time here and I could not be more proud to be counted as one of your first students. You are an incredible teacher and mentor, and I will be forever thankful for your guidance. Thank you for always believing in me. I dedicate this thesis to you.



## TABLE OF CONTENTS

ACKNOWLEDGEMENTS.....	1
LIST OF TABLES.....	1
LIST OF FIGURES .....	1

### Chapter

1. COMMON LOON ( <i>GAVIA IMMER</i> ) BIOGEOGRAPHY AND REPRODUCTIVE SUCCESS IN AN ERA OF CLIMATE CHANGE: BACKGROUND AND CONCLUSIONS.....	1
1.1. DISTRIBUTION .....	1
1.2. HABITAT.....	2
1.3. FEEDING .....	3
1.4. PHYSICAL CHARACTERISTICS .....	3
1.5. BEHAVIOR.....	4
1.6. BREEDING INFORMATION .....	5
1.7. SITE FIDELITY .....	6
1.8. MANAGEMENT AND CONSERVATION.....	8
1.9. RANGE EDGES.....	8
1.10. CLIMATE CHANGE.....	9
1.11. MODELING SPECIES DISTRIBUTION IN RESPONSE TO CLIMATE CHANGE.....	10

1.12. LAKE METRICS PREVIOUSLY SHOWN TO AFFECT LOON	
PRESENCE/ABSENCE AND PRODUCTIVITY .....	11
1.12.1. Lake Depth .....	11
1.12.2. Lake Surface Area .....	12
1.12.3. Water Clarity/Turbidity .....	13
1.12.4. Surface temperature .....	13
1.12.5. pH .....	14
1.12.6. Conductivity .....	15
1.12.7. Dissolved Organic Carbon (DOC).....	16
1.13. USING TRIGLYCERIDES AND FREE GLYCEROL TO DETERMINE	
ENERGETIC COST .....	17
1.14. SYNOPSIS .....	25
2. MACHINE LEARNING TECHNIQUES: A TOOL FOR UNDERSTANDING COMMON	
LOON (GAVIA IMMER) BIOGEOGRAPHY AND PRODUCTIVITY IN AN ERA OF	
CLIMATE CHANGE .....	29
2.1. ABSTRACT .....	29
2.2. INTRODUCTION .....	30
2.2.1. Climate Change and Freshwater Communities .....	30
2.2.2. Machine Learning: Using Decision Trees and Random Forests to	
Determine Variable Importance .....	32
2.2.3. General Approach.....	34
2.3 METHODS .....	35
2.3.1. Methods Overview .....	35

2.3.2. Continental-scale Range Descriptors.....	36
2.3.3. Regional-scale Range Descriptors.....	45
2.3.4. Regional Productivity Descriptors.....	46
2.4. RESULTS.....	48
2.4.1. Continental-scale Range Descriptors.....	48
2.4.2. Regional-scale Range Descriptors.....	52
2.4.3. Regional Productivity Descriptors.....	55
2.5. DISCUSSION.....	58
2.5.1. Continental-scale Range Descriptors .....	58
2.5.2. Regional-scale Range Descriptors.....	62
2.5.3. Regional-scale Productivity Descriptors .....	63
2.5.4. Validating Envelope Models with Hierarchical Decision Trees .....	64
2.5.5. Implications for Climate Change on the Range of the Common Loon ..	66
3. BLOOD METABOLITES AS INDICATORS OF BREEDING HABITAT QUALITY: A SENSITIVE METHOD TO PREDICT RANGE ALTERATION UNDER CLIMATE CHANGE?.....	68
3.1 ABSTRACT .....	68
3.2 INTRODUCTION .....	69
3.3 MATERIALS AND METHODS .....	73
3.3.1. Study population, field methods, and lab assays .....	73
3.3.2. Behavioral Observations.....	74
3.3.3. Statistics.....	75
3.4 RESULTS.....	78

3.4.1. Establishing Baseline Metabolic Measures .....	78
3.4.2. Triglyceride Levels In Breeding Loons .....	79
3.4.3. Behavior .....	82
3.5 DISCUSSION.....	83
3.6 SUMMARY.....	87
BIBLIOGRAPHY .....	89
BIOGRAPHY OF THE AUTHOR.....	101

## LIST OF TABLES

Table 1. Descriptive Statistics for Metabolite Values.....	18
Table 2. Data Sources.....	37
Table 3. Variables in National Presence/Absence Analysis.....	40
Table 4. Variables in New England Presence/Absence Analysis.....	46
Table 5. Variables in New England Productivity Analysis.....	48
Table 6. Descriptive Statistics for Triglyceride and Free Glycerol Levels.....	79
Table 7. Triglyceride Probability Models.....	81
Table 8. Triglyceride Model-Averaged Parameter Estimates.....	82
Table 9. Triglyceride Levels of Loons That Escalated Interactions with Intruders.....	83

## LIST OF FIGURES

Figure 1. Portion Of A Figure From Jenn-Eiermann and Jenni (1994) .....	20
Figure 2. Figure From Jenni-Eiermann And Jenni (1992) .....	22
Figure 3. Figure From Jenni and Schwilch (2001) .....	24
Figure 4. Determining Loon Presence/Absence .....	37
Figure 5. Lakes Used In Analysis.....	38
Figure 6. Map For Determining Lake Inclusion. ....	39
Figure 7. United States Classification Tree .....	49
Figure 8. Random Forest Analysis For United States.....	51
Figure 9. Dependence Plots for United States Analysis .....	52
Figure 10. Classification Tree For New England .....	53
Figure 11. Random Forest For New England Analysis .....	54
Figure 12. Dependence Plots For New England Analysis .....	55
Figure 13. Regression Tree For Productivity Model .....	56
Figure 14. Random Forest For Productivity Analysis .....	57
Figure 15. Temperature/Year Interaction Plot. ....	87

## **CHAPTER 1**

### **COMMON LOON (*GAVIA IMMER*) BIOGEOGRAPHY AND REPRODUCTIVE**

#### **SUCCESS IN AN ERA OF CLIMATE CHANGE:**

#### **BACKGROUND AND CONCLUSIONS**

#### **STUDY SPECIES: THE COMMON LOON**

##### **1.1. DISTRIBUTION**

The world population size of the common loon is estimated at 615,000 individuals (Evers et al. 2010). Loons breed on freshwater lakes throughout Canada and several northern states in the U.S. (including parts of Washington, Idaho, Montana, Wyoming, North Dakota, Minnesota, Wisconsin, Michigan, New York, Maine, Vermont, New Hampshire, and Massachusetts). The northern edge of their breeding range extends to Alaska and the taiga shield forest ecosystem of Canada (Evers et al. 2010).

Historically, loons have been reported to breed in locations further south than their current distribution with confirmed breeding in areas of Northeast California, Northern Iowa, Southern Minnesota, Northern Illinois, Southern Wisconsin, Northern Indiana, Southern Michigan, Northern Ohio, and Northeast Pennsylvania; however, availability of information on past distributions is geographically and temporally sporadic. Loons began breeding in Northern Massachusetts approximately 40 years ago and in parts of Pennsylvania 30 years ago, which represents either a range expansion or a recolonization of their former range in these areas (Evers et al. 2010).

Loons winter on the Atlantic and Pacific Oceans. In the Atlantic, the range extends from northern Canada along the coast of Newfoundland to the Gulf of Mexico. Pacific Ocean wintering distribution ranges from the Aleutian Islands off of Alaska to the Gulf of California (Evers et al. 2010). Loons largely remain on inshore ocean waters and will use inlets and coves during the winter. Loons prefer water depths less than 19 m deep, but will also utilize waters 100 m deep and 100 m from shore, largely depending on prey movement and availability (Kenow et al. 2009). While rare, there have been reports of overwintering loons on freshwater systems in the southern United States (Evers et al. 2010).

## **1.2. HABITAT**

During the breeding season, loons prefer freshwater lakes that are greater than 24 acres in size and that have irregular shorelines that create inlets and coves suitability for nesting. Rivers are rarely used for nesting habitat unless large areas with little current are available (Evers et al. 2010). Water quality characteristics are important for habitat as loons are visual, underwater predators (Barr 1973). Adults feeding in turbid water spend twice as long capturing prey as those in clear waters (Gostomski and Evers 1998). Total lake surface area, depth, and surface temperature have been shown to be significant predictors of loon presence or absence on lakes in New Hampshire (Blair 1992).

Loons also use lakes and large rivers as staging areas during spring and fall migration to rest and forage. These lakes and rivers have similar characteristics to breeding lakes, such as clear water and abundant prey (McIntyre and Barr 1983). Typically young will leave their natal territories and not return to freshwater lakes until



roughly 3-4 years of age (Evers et al. 2010). There have been, however, reports of juveniles in basic plumage on the breeding grounds during summer months (Ewert 1982).

### **1.3. FEEDING**

Loons are primarily piscivorous birds that use visual, subsurface pursuit to capture prey (Barr 1973). Preferred prey fish are those which swim somewhat erratically such as yellow perch (*Perca flavescens*), pumpkinseeds (*Lepomis gibbosus*) and bluegill (*Lepomis macrochirus*). Most prey items are consumed underwater; however larger items are frequently brought to the surface for manipulation prior to swallowing (Barr 1973). Pursuit of fish usually occurs in shallow waters less than 5 meters deep in areas within 50 – 150 m of shoreline, where preferred prey items are usually located (Ruggles 1994). Loons supplement their diets with aquatic arthropods and macroinvertebrates, though underwater consumption of prey makes it difficult to quantify the proportion of the diet that these items comprise (Gingras and Paszkowski 2006). Chicks are fed a diet of fish and aquatic invertebrates (especially crustaceans) above the surface of the water (Barr 1973, Alvo et al. 1988).

### **1.4. PHYSICAL CHARACTERISTICS**

Some physical characteristics of loons are distinctive and set them apart from other water birds. Loons are sexually monochromatic during both the breeding and non-breeding season. They exhibit a degree of size dimorphism, with males generally weighing 27% more than females, though this is often difficult to quantify in field observations. The body mass of loons in Maine is between 2780-5400 grams. The legs of loons are positioned towards the back of their bodies which aids in swimming and underwater maneuvering, yet this positioning makes it impossible for loons to walk

upright on land. Instead, loons must push themselves on their ventral surface when it is necessary to travel on land, such as during copulation, nest building, or incubation. Their heavy body weight and shorter wing span relative to body size makes it difficult for loons to take flight from the surface of the water. Often, they need upwards of 200 m to build up the speed to take flight, though strong winds will greatly reduce the distance needed for take-off. Adults can increase or decrease the amount of air in their air sacs and thus vary the depth at which they float at the surface of the water (Evers et al. 2010).

## **1.5. BEHAVIOR**

Loons are conspicuous birds that are known for their unique behaviors. They spend the majority of their time floating on the surface of the water and when searching for food they will often “peer” underwater before committing to diving after prey (Evers et al. 2010). This peering behavior is also seen when loons are interacting with territorial intruders. Loons will dip their heads below the surface of the water as two or more individuals swim in a circle (pers. obs.). Aggressive interactions escalate from here and include splash-diving (a dive beneath the surface that is more forceful than typical foraging dives), bill striking, “penguin dancing” (the loon pulls almost the entirety of its body out of the water and propels itself with its feet across the surface of the water), “wing rowing” (where loons propel themselves quickly across the surface of the water using their wings as oars, often in pursuit of a rival), and grabbing of a rival loon’s head or bill. Once two rivals have locked bills, individuals will hit each other with their wings and/or one rival’s head will be held underwater. Fights between conspecifics can result in death, often by drowning or bill puncture wounds incurred when loons fight underwater (Piper et al. 2008b, Evers et al. 2010).

There are a variety of behaviors performed by loons on a regular basis that are largely involved in maintenance. These behaviors include head scratching, bathing, stretching, preening and sleeping. Loons will perform a foot waggle, which is when one foot is pulled out of the water and shaken and often remains out of the water, either extended or subsequently tucked beneath the wing. This action is thought to primarily service as a comfort movement, but it has also been speculated to serve an indirect function in thermoregulation (Paruk 2009).

Loons are known for their loud, eerie vocalizations. Only males perform the yodel call, which is a high amplitude call that carries a long distance (Olson and Marshall 1952) and provides information regarding a male's motivation, condition, and identity (Mager et al. 2007). Both males and females will vocalize using tremolos and wails, and also create quieter sounds called "mews" and "hoots" (Mager and Walcott 2007).

## **1.6. BREEDING INFORMATION**

Loons are monogamous on the breeding grounds and genetic studies have not found evidence of extra-pair mating (Piper et al. 1997a). The courtship ritual of loons consists of bill dipping, circular swimming, and synchronous diving. Common loons have much stronger breeding site fidelity than mate fidelity (Evers et al. 2010). The pair bonds last, on average, 5 years. If one of the pair members does not return to the breeding site, it will be replaced through the passive occupation of another individual. Loons will also attempt to usurp an individual from its territory through aggressive encounters (41% of territory turnovers), which sometimes result in the death of one of the combatants (Piper et al. 2000, 2008b). Loons are highly territorial during the breeding season (Evers et al. 2010).

The female lays 1-2 eggs and both parents alternate incubation duties for 26-31 days and mutually care for the semi-precocial young (Evers et al. 2010). The sex ratio of chicks is very close to 50:50 (Evers 2001a, Piper et al. 2008a). Loons prefer to nest on islands over mainland sites and will nest on artificial islands, natural islands, or on floating bog mats. When nesting on the shoreline, loons prefer soft-edged locations on the lee side of the lake with enough water for an underwater approach (Evers et al. 2010).

Generally, females return to nesting territories from their wintering grounds before males (Evers et al. 2010). Territories are of three specific types: multi-lake, in which pairs must visit more than one lake in order to meet their nutritional requirements; single lake, in which pairs are the only loons present for a given body of water; and shared lake, where more than one pair nests on a given lake (Piper et al. 1997a).

### **1.7. SITE FIDELITY**

There are many advantages to returning to a breeding site year after year, including knowledge of potential nesting sites, information regarding prey availability and distribution, and familiarity with the presence of predators (Greenwood and Harvey 1982). Furthermore, returning to a previously used site increases chances of re-pairing with the same partner. This may increase efficiency in nesting activities through reduced time needed to become familiar with a mate (Rowley 1983), which may lead to increased nesting success. Another advantage is familiarity with nearby territory holders which could reduce the need for boundary disputes and aggressive interactions (Stamps 1987).

There have been many studies citing a positive correlation between reproductive success and continued site fidelity (reviewed by Switzer 1997). On the contrary, poor nesting success may cause birds to change territories and/or mates more readily the

subsequent year (Payne and Payne 1993). In birds, those that breed successfully are more likely to return to a given site and have shorter dispersal distance if they do move (Drilling and Thompson 1988). It is thought that breeding site fidelity is an adaptive response as successful breeders can return to the area where they previously had success and unsuccessful breeders can try elsewhere (Sedgwick 2004). It has been demonstrated in passerines that they will use information from the previous breeding season to make choices regarding breeding site use in the subsequent year (Doligez et al. 1999).

Both site fidelity and mate fidelity have been studied in loons. There is sex-biased familiarity with breeding sites in loons, as only males have been found to choose nest site locations. Therefore, it appears no benefit is gained from an increased tenure of female loons on a territory in regards to nest site selection, and novel males experience a “Familiarity deficit”, a reduced knowledge of successful nesting locations compared to a long-term resident, regardless of the territorial tenure of his mate (Piper et al. 2008a). Piper et al. (2008b) speculated that territories containing many high-quality nesting sites (i.e. island habitats a fair distance from shoreline) would have a small familiarity deficit, and thus there should be an increase in attempts at territorial evictions on these territories. On the other hand, territories that lack abundant suitable nesting sites should experience fewer eviction attempts. Alternatively, the reconnaissance hypothesis states that territorial take-overs are more likely to occur on territories that have successfully produced chicks the previous year, indicating that loons are monitoring the outcomes of nesting attempts by other pairs (Piper et al. 2000).

## **1.8. MANAGEMENT AND CONSERVATION**

The population growth of common loons (*Gavia immer*) has slowed during the last 20 years (Gear et al. 2009). There are various explanations as to why this is occurring, including lead poisoning from fishing weights (Pokras et al. 1998), increased human activities on lakes (Hemberger et al. 1983), changes in land use (Lindsay et al. 2002), and increased mercury in the environment (Kenow et al. 2007). It is also possible that the recent decrease in growth may be a result of density dependence, which is supported in some regions by increases in aggressive interactions between nonbreeding adults and territorial pairs (Gear et al. 2009, Piper et al. 2000, 2006).

## **BACKGROUND INFORMATION**

### **1.9. RANGE EDGES**

Determining the reasons for a species' distribution can vary from quite clear, as when a species is strongly tied to a particular resource, to incredibly complex due to the interplay of various competing ecological and evolutionary dynamics. Studying species on the edge of their range and understanding their distribution necessitates the consideration of adaptive evolution and demographic processes (Holt and Keitt, 2005). Additionally, species distributions must be considered within context of interactions with other species in regards to predation and competition (Gaston, 2003).

Gaston (2003) outlined a three-question framework for examining species and their associated range edges. First, one must consider the biotic and abiotic factors that limit further spread. Examples of these factors are physical barriers or a lack of available resources. Secondly, one must address how these factors manifest themselves in terms of

population dynamics (i.e. immigration, emigration, etc.). Lastly, one must consider the genetic basis for the limit of a species' geographic range. Using these questions as an outline allows for a comprehensive approach to address spatial distribution.

Often, current models for determining distribution are linked solely to correlations with ecological parameters and thus are limited in their abilities to predict ranges (Thuiller 2003). The development of fully dynamic models linking species' ranges to ecological and demographic processes that occur throughout the biogeographic range are necessary to predict the effects of habitat degradation and loss in times of a changing climate and rapid landscape evolution (Holt and Keitt, 2005).

#### **1.10. CLIMATE CHANGE**

Climate change in the coming century is predicted to cause a suite of effects on the global environment (IPCC, 2007). Among the projected changes are an increase in mean surface air temperature, an increase in the concentrations of carbon dioxide in the atmosphere, increases in concentrations of other greenhouse gases (i.e. methane, nitrous oxide, tropospheric ozone), warming of mean sea-level temperature, and a rise in global mean sea-level (Watkinson et al. 2004). Additionally, predicted changes in seasonality of precipitation could greatly impact the structure of existing ecosystems (Watkinson et al. 2004).

Regional changes in New England are predicted to increase levels of precipitation, extend drought periods, and increase air temperatures, and these changes will likely alter freshwater ecosystems (Poff 2002). For example, a prolonged drought can alter the movement of solutes and water to a lake, in turn modifying the lake chemistry (Magnuson et al. 1997). All three climate divisions of Maine (Coastal,

Northern, and Southern Interior) are warmer and wetter than they were 30 years ago (Jacobson et al. 2009). Increases in both air and water temperatures will most likely affect the production, abundance, and distributions of plants in lakes and streams (Jacobson et al. 2009). On an extremely localized level, stream flow has been linked to regional and global climate factors (Kingston et al. 2007).

### **1.11. MODELING SPECIES DISTRIBUTION IN RESPONSE TO CLIMATE CHANGE**

One of the most common ways to determine possible changes in bird species' distribution due to changing climate is through the use of bioclimatic envelope models. These models link the current geographical distribution of a species to climatic variables and then the future predicted location of this 'envelope' is used to predict where species will occur under climate change scenarios (Heikkinen, 2006).

There are various opinions regarding the validity of modeling changes in distribution using 'envelope' models, some of which support this method and others that refute it (Pearson and Dawson 2003, Hampe 2004, Thomas et al. 2004, Hijmans and Graham 2006, Heikkinen et al. 2006, Beale et al. 2008, Vallecillo et al. 2009). Most researchers agree that this method is only a first step in determining the predicted changes in distribution, and they should only be used as guidelines for further investigation. In fact, a recent study by Beale et al. (2008) found that when they made real and artificial 'envelope' models for 100 different birds species, associations between species and climate determined by climate envelope models are no better than chance (those made artificially) for 68 of the species tested. Possible reasons for this result is the possibility that distributions may not match climate (Beale et al. 2008) and may, in fact, be



explained better by land cover, biotic interactions, dispersal, or adaptive evolution (Davis et al. 1998a, Thomas et al. 2001, Heikkinen et al. 2006). Additionally, future conditions may include greater habitat fragmentation, species-specific responses to increased CO<sub>2</sub> levels, soil and fire changes, and interactions of genetic differences as species are brought together or separated (Heikkinen, 2006). These possible changes cannot be accounted for by current envelope modeling techniques.

A better approach to modeling potential changes in species distribution is through the inclusion of additional factors thought to influence a species' current distribution. It is also important to take into account the influence of species-specific interactions and changes in human activity. Metrics that are specific to the species and can be shown to influence the demographic processes underlying range edges would be the most valuable for determining how changes in these parameters may alter future distributions.

## **1.12. LAKE METRICS PREVIOUSLY SHOWN TO AFFECT LOON PRESENCE/ABSENCE AND PRODUCTIVITY**

We included variables in our analysis (Chapter 2) that were important for loons in smaller scale studies or variables that we hypothesized might be so on a continental scale. As a means of testing potential drivers of range change, we included all of the following characteristics in our nation-wide presence/absence database (and as many as possible in the smaller datasets):

### **1.12.1. Lake Depth**

Alvo et al. (1988) found that lake depth provided significant discrimination between lakes where chicks were successfully raised versus where they failed. In a study of the potential effects of climate change on freshwater systems in New England, Moore

et al. (1998) determined that under a 3-5 °C climate change, annual stream flow will decrease by 21- 31%. These analyses were conducted for a doubling of atmospheric CO<sub>2</sub> which is projected to occur in the early half of the next century (IPCC, 2007). Additionally, predicted decreases in snowpack and increases in spring precipitation events may lead to an earlier, yet smaller, pulse of water in spring (IPCC, 2007). Decreases in seasonal runoff would most likely produce lower lake levels. Reservoirs may be able to compensate for this change through alterations in dam operation; however power companies may be forced to draw off water more rapidly during the loon breeding season to match increased demands.

### **1.12.2. Lake Surface Area**

Alvo et al. (1988) found that lake surface area provided significant discrimination between lakes where chicks were successfully raised versus where they failed. In this study, lake area was related weakly but significantly to depth, and neither depth nor area was related to water chemistry variables. The volume of water in a lake is related to the surface area, and runoff decreases for the reasons mentioned above, so too may lake surface area. The trophic system of a lake is dictated by lake volume, water residence time, and the available nutrients that flow into the lake from the surrounding drainage basin (Wetzel, 2005). Lake trophic states may then be altered or disrupted by climate change (IPCC, 2007), through anthropogenic changes in nutrient enrichment, or other changes to the drainage basin (Wolfe et al. 2001). These changes have the potential to affect the food webs upon which loons rely (Evers et al. 2010; McIntyre, 1994)

### **1.12.3. Water Clarity/Turbidity**

Water clarity affects loon's ability to see prey items such as fish and other aquatic vertebrates (McIntyre and Barr, 1997). When water visibility is less than 1 meter, crayfish (decapod crustacean) constitute up to a third of a loon's diet (Barr, 1973). A Wisconsin-based study by Lathrop et al. (1999) found that one third of year-to-year water clarity differences in the summer were due to runoff variability. Increased nutrient input leads to increased phytoplankton levels which, in turn, decreases water clarity. Predicted increases in extreme rainfall events with climate change will increase the influx of nutrients and sediments into streams and lakes, and this effect would be exacerbated if these rainfall events occurred in areas with bare agricultural fields in the drainage basin (IPCC, 2007). Vertical mixing explains a second third of water clarity variation. Warmer temperatures can lead to less mixing which often results in greater water clarity (IPCC, 2007). While turbidity will potentially increase or decrease on the local level due to climate change, it is clear that any decreases in water clarity will result in diminished foraging success for the common loon (Gostomski and Evers 1998).

### **1.12.4. Surface temperature**

Blair (1992) studied the association of loon presence with 37 different lake characteristics in New Hampshire. Surface temperature was determined to be one of the top three predictors of presence (along with surface area and lake depth) during the breeding season. This correlation may exist due to the effects of temperature on fish distributions and growth and activity rates (Moyle and Cech, 2004).

Global temperatures are predicted to increase between 1-7°C in the next 100 years, with the magnitude of regional temperature difference predicted to be larger at

higher latitudes (IPCC, 2007). Increases in local temperature would logically increase lake surface temperatures (Ficke et al. 2007). Biochemical reactions are dictated by fish body temperature and therefore projected changes in water temperature will influence physiological processes in fish (i.e. growth rates, metabolism, reproductive success, etc.). Alterations in water temperature regimes are predicted to alter species abundances, change available fish biomass, and shift current distributions (Ficke et al. 2007). Additionally, rising water temperature will increase lake stratification duration and strength as a warmer epilimnion increases density gradients in a way that is more resistant to mixing (Peeters et al. 2007). Changes in stratification will decrease availability of dissolved oxygen to the hypolimnion and alter algal assemblages, food web dynamics, and the available suitable habitat for fish (Ficke et al. 2007). While loons are adapted to surviving on various different prey items (Evers et al. 2010), large-scale shifts in prey composition could potentially push loons out of once suitable breeding lakes.

#### **1.12.5. pH**

Alvo et al. (1988) reported an inverse relationship between loon breeding success and lake pH. McNicol et al. (1995) found that loons were less likely to nest on acidic lakes (with pH less than 5.5), and those that did had lower reproductive success. Further, high alkalinity lakes in Ontario were associated with successful breeding in loons (Alvo and Berrill, 1986). Alvo and Berrill (1986) speculated that this link between productivity and pH was due to low food levels available for the offspring (adults could forage elsewhere when necessary). When adjusted for age, Merrill et al. (2005) found there was a decline in food intake for loons on lakes with low pH. In this intensive study, however,

the reason for this decline was found to be due to reduced numbers of loon dives in acidic lakes and not because of a reduction in provisioning time.

Contrary to these results, Badzinski and Timmermans (2006) found that there was no correlation between loon productivity and lake acidity. They speculated that this conflicting result was due to the predominance of lakes with neutral pH in this study location in Nova Scotia, Canada (<10% had a  $\text{pH} \leq 5.5$ ). Parker (1988) found that there was no relationship between low pH lakes and loon reproductive success, however the chicks on low pH lakes were fed smaller prey items, and the adults spent up to four times more time feeding their offspring than adults on lakes with higher pH.

Changes in pH, acidification, and recovery of acidified lakes are projected to be impacted by climate change through increases in atmospheric acidic deposition (Magnuson et al. 1997, IPCC 2007). Depending on the position in the drainage basin, lakes that receive less groundwater would be particularly vulnerable to acidification in drier years (Webster et al. 1996). The inclusion of a larger set of lakes for analysis at a continental scale will provide us with a more complete understanding of the effect of acidification on loon presence and reproductive success.

#### **1.12.6. Conductivity**

Conductivity is a numerical value that corresponds to a water body's capacity to carry an electrical current (Wetzel, 2005). This value is directly related to the number of dissolved ions (charged particles) in a given water body. Increases in lake pollutants, such as sediments, inorganic elements (e.g. sodium, chlorine, sulfur), and organic elements (i.e. decaying biological material, human made compounds) can increase measures of conductivity, therefore acting as an indirect measure of pollution (Gleick et

al. 2002). Baseline measures of conductivity have the potential to indicate loon presence on a lake. Alvo et al. (1988) found a high correlation between conductivity, alkalinity, and pH, and these three factors together accounted for 46% of the habitat variability in their study of loon breeding lakes in Canada (using principal component analysis). Blair (1992), however, found no association between conductivity and loon presence/absence on a given lake.

Human activities, such as urban or agricultural runoff, road salting, and leaking septic waste systems are the leading contributors to increasing lake conductivity. Additionally, new development or increased agriculture in a drainage basin can expose new bedrock or soils and alter runoff patterns (Dale, 1997), which can increase conductivity (Wetzel, 2000). Most alterations to landscapes occur on a regional scale and thus the likelihood of modifications under climate change conditions is best considered on a case-by-case basis using spatially explicit models. The proximity of a lake to large urban centers, the feasibility of land for conversion to agriculture, or the availability of resources (such as timber for harvesting) are all factors that determine potential land-use changes and the ionic concentrations of runoff (Dale, 1997).

#### **1.12.7. Dissolved Organic Carbon (DOC)**

Badzinski and Timmermans (2006) found that there was no effect of DOC on loons rearing one chick, however, adults rearing two chicks were more successful on low DOC lakes. High concentrations of DOC (particularly on lakes with low pH) reduce mercury availability to fish (Driscoll et al. 1995). The resulting reduced mercury risk to loons may explain the higher success rate on lakes with higher DOC (Badzinski and

Timmermans, 2006). High DOC also decreases water clarity (Wissel et al. 2003), making visual hunting more difficult for loons.

DOC is the product of the degradation of living material, and as such, it plays an important role in the cycling of carbon in aquatic environments (Hader et al. 1998). Projected decreases in stream flow will decrease the influx of organic material from the lake catchment (Schindler et al. 1997). Additionally, climate change will allow for an increased penetration of ultraviolet light (UV-B) and photosynthetically active radiation (PAR) into lakes (Schindler et al. 1997), resulting in decreased bioavailable DOC (Hader et al. 1998). While decreased DOC would increase loon visibility for foraging, DOC also provides the base of the bacterioplankton food web, and changes in the phytoplankton community would have consequences throughout the food chain (Ficke et al. 2007).

### **1.13. USING TRIGLYCERIDES AND FREE GLYCEROL TO DETERMINE ENERGETIC COST**

Plasma metabolites will give a snap-shot indication of energetic condition through comparison of blood triglyceride and glycerol measures amongst individuals. High levels of triglycerides will indicate that a loon is acquiring fat reserves whereas an elevated level of glycerol is evidence of the use of stored fat reserves; however caution must always be exercised when interpreting metabolite results. A loon in a more compromised energetic state (as evidenced by higher levels of glycerol) will presumably be more physiologically taxed and less likely to maintain healthy chicks. In Chapter 3, I analyze loon metabolites to determine whether physiological indicators of lipid anabolism/catabolism vary across habitat and territory types in adult loons.

**Table 1. Descriptive Statistics for Metabolite Values.** Descriptive statistics for the average triglyceride and glycerol levels of common loons (*Gavia immer*) with chicks in areas of ME, NH, MA, MT, WA during the summer of 2010 and 2011.

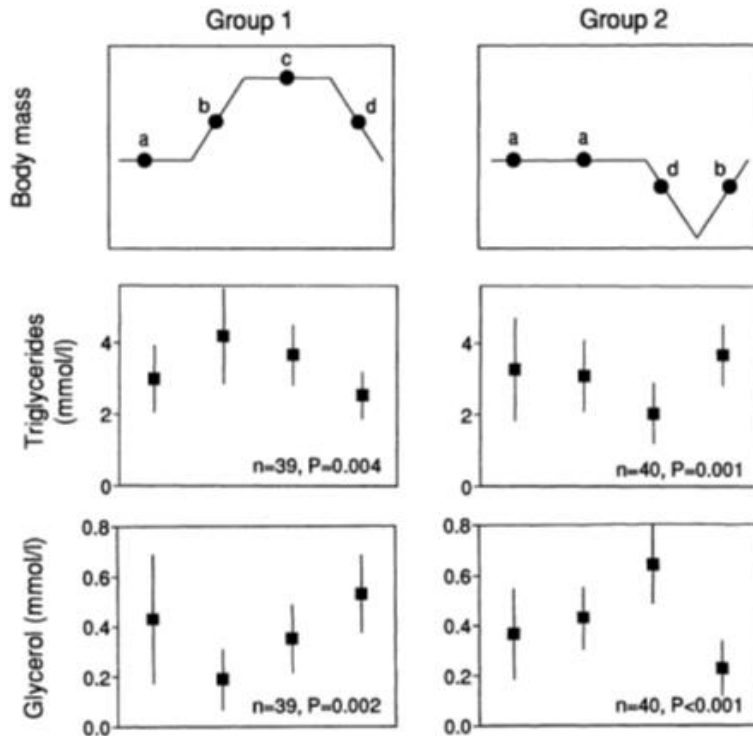
	n	mean	SD
Free Glycerol (mmol/L)	105	0.157	0.080
Triglycerides (mmol/L)	105	0.875	0.376

Previous studies have used measures of glycerol and triglycerides to examine energetic costs to individuals, and these findings can place our results (Table 1) in a proper physiological context. In the remainder of this section, I attempt to demonstrate that: 1) our findings for loons show similar triglyceride and free glycerol values to other studies, 2) triglyceride and free glycerol correlate with condition, 3) this correlation varies depending on metabolic activity and/or food intake, 4) metabolites track condition better than mass or activity measurements, and 5) you can use a single measure of triglycerides and free glycerol to track condition.

As outlined by Jenni-eiermann and Jenni (1998), the physiological state in animals is mostly a function of both feeding and metabolic rates, and the precise location of an individual along both of these axes can be assessed by their blood metabolites and the gross condition of their tissues which cover a continuous range: 1) feeding birds with a mid-level metabolic rate (the resorptive state), 2) fasting birds that are inactive, 3) fasting birds with a high metabolic rate (e.g. during migration), 4) starved birds that are inactive, and 5) starved birds with a high metabolic rate (e.g. flight). More generally, individuals can be assigned to one of three basic energetic states: net positive energy budget, net negative energy budget, and stasis.



In our study, each loon could only be captured one time and it was important that we could use a single measure to interpret results. Jenni-Eiermann and Jenni (1994) designed a study to help understand the plasma metabolite readings of birds only caught one time. In their experiment, they found that 61% of the changes in body mass were explained by triglycerides and  $\beta$ -hydroxy-butyrate. Free glycerol levels were found to be lowest when an individual's body mass was increasing and highest when body mass was decreasing in a study of garden warblers (*Sylvia borin*), however glycerol levels were of an intermediate level when fat reserves were stable (Fig. 1; Jenni-Eiermann and Jenni, 1994). In this same study, triglyceride levels followed the opposite pattern where the highest values occurred during fattening and the lowest values occurred during fat loss (Fig. 1). In our study, the values we found for free glycerol are similar to the low points graphed in the free glycerol row (Fig. 1). Lower glycerol values in the Jenni-Eiermann and Jenni (1994) study corresponded to either stable mass or increasing mass. In their study, increases in mass are either from an average mass to a surplus of fat, or an increase in mass from a highly depleted state. Our values for triglycerides (Table 1) averaged much lower than any of the values in the Jenni-Eiermann and Jenni (1994), however, we interpret our results as being most similar to that of Group 2, letter b (Fig. 1). Among our low levels of free glycerol, therefore, we examined differences in the values of triglycerides as indicators of differences in energetic demand as they circulated more or less fatty acids (bound to glycerol) in their bloodstreams.



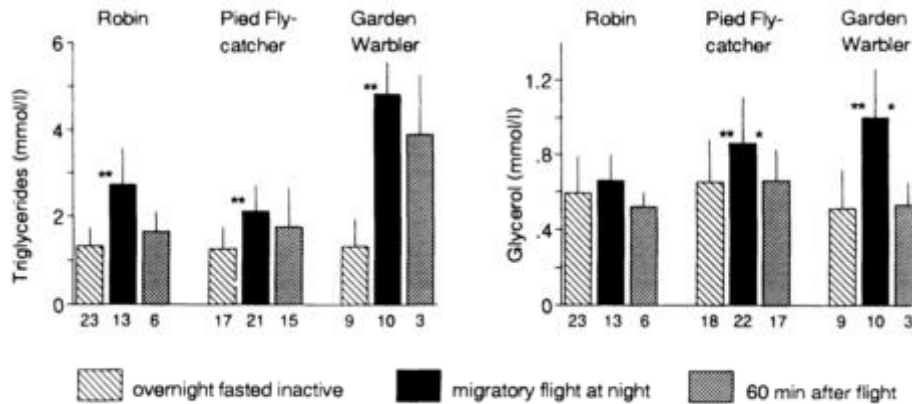
**Figure 1. Portion Of A Figure From Jenn-Eiermann and Jenni (1994).** Relevant figure information has been included. “Mean values ( $\pm$ SD) of metabolite concentrations, and proportion of two electrophoresis peaks for the four body-mass conditions of each experimental group. Probability values concern differences among body-mass conditions (two-way ANOVA without replication). There were no significant added variance components among birds, except for triglycerides of group 2 ( $P = 0.004$ ). Sample size 10 for each mean value.”

As common loons are breed on lakes and winter in the ocean, here I present a study of other seabirds which have comparable physiological requirements to loons. In 1997, Newman et al analyzed blood from 13 species of pelagic marine birds in order to establish baseline plasma biochemical ranges in wild Pacific seabirds. Free glycerol levels were not reported in this study. Birds were sacrificed from the Shumigan Islands, AK, between June 9<sup>th</sup> and June 17<sup>th</sup>, 1990. Species collected included ancient murrelet (*Synthliboramphus antiquus*), black-legged kittiwake (*Rissa tridactyl*), Cassin's auklet (*Ptychoramph marmoratus*), common murre (*Uria aalge*), crested auklet (*Aethia*

*cristatell*), glaucous-winged gull (*Larus glaucescen*), horned puffin (*Fratercula corniculata*), marbled murrelet (*Brachramphu marmoratus*), northern fulmar (*Fulmarus glacialis*), parakeet auklet (*Cyclorrhynchusa psittacula*), pelagic cormorant (*Phalacrocorax pelagicus*), pigeon guillemot (*Cepphus columba*), tufted puffin (*Lunda cirrhata*). Across all seabirds combined, the researchers found significantly higher triglyceride levels in females versus males, but no significant relationships between triglyceride levels in measures of breeding condition. The average triglyceride value for males was 2.484 ( $\pm 2.698$ ) mmol/L and for females it was 4.177 ( $\pm 5.430$ ) mmol/L. As there is a large amount of variance around these results, we find our triglyceride levels fall within this range.

The correlation of triglycerides and free glycerol depend on metabolic activity which can aid in understanding differences in physical exertion in loons. Jenni-Eiermann and Jenni (1992) examined triglycerides and glycerol levels in the night-migrating birds the European robin (*Erithacus rubecula*), garden warbler (*Sylvia borin*), and pied flycatcher (*Ficedula hypoleuca*). In all three of these species, triglyceride and glycerol levels were significantly higher in birds that were flying overnight than in those that fasted overnight, because they were mobilizing fats to burn while flying (Fig. 2). The higher plasma triglyceride and glycerol values during migration are due to the release and transport of fatty acids from adipose tissue to flight muscles at an accelerated rate. One hour after migratory flights, however, triglycerides remained high (as fat deposits are being rebuilt) while glycerol is similar to fasting levels (as the rate of tissue turnover is slow again). Our glycerol and triglyceride levels are much lower than those of the migrating birds, although they are similar to those of the birds with lower metabolic rates

(the overnight fasted inactive birds or the 60 minutes after flight birds: Fig. 2). Given this relationship, we are able to predict metabolite concentrations for loons in different energetic conditions (assuming a similar metabolic rate).



**Figure 2. Figure From Jenni-Eiermann And Jenni (1992).** “Means  $\pm$  SDs of plasma fat metabolite concentrations and of the percentage of fraction 1 in lipoprotein electrophoreses of three species of birds in three physiological situations. Numbers below the bars denote the sample sizes. Significance of the difference between adjacent samples (Mann-Whitney U-test) is shown in asterisks: \*,  $P < 0.05$ ; \*\*,  $P < 0.01$ .”

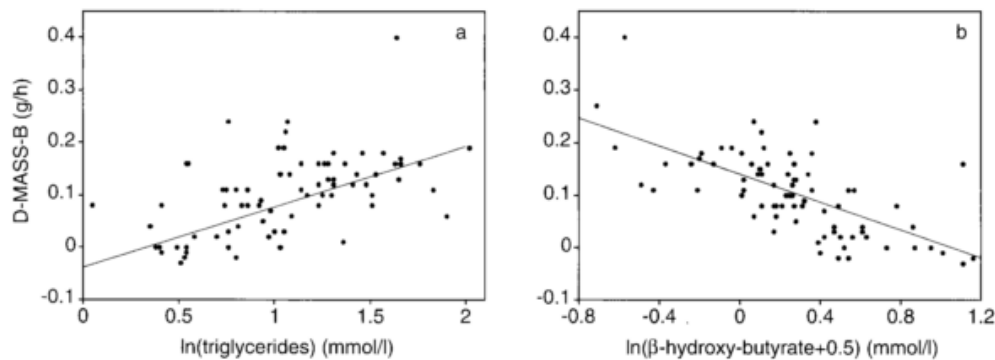
As all of the loon captures in this study were performed at night when loons are not feeding, it is helpful to understand the dynamics between fasting and metabolite levels. Alonso-Alvarez and Ferrer (2001) examined glycerol and triglycerides in yellow-legged gulls (*Larus cachinnans*) at various stages of fasting. In this study, they found that plasma triglycerides steadily decreased throughout fasting (over a two week period). On the first day of fasting, gull triglyceride levels were 0.854 mmol/L ( $\pm$  0.117 SD), which is exactly our mean nightly average for loons, and these values fell to 0.605 mmol/L (0.113) after two weeks of fasting. For gulls with a restricted diet (limited sardines fed), the triglyceride levels were similar on the first day ( $0.832 \pm 0.056$  mmol/L), and fell even further to 0.364 mmol/L (0.050) after two weeks of dietary restriction. The

lowest triglyceride value in my data set was 0.120 mmol/L and so lower triglyceride levels are thus likely predicted by decreases in energetic condition. Totzke et al. (2009) examined the influence of fasting on herring gulls (*Larus argentatus*). Glycerol was not measured in this study. Birds were starved for six days, but the initial days of the experiment are most comparable to our values. During day 0-1 of fasting, triglyceride levels were 1.2 mmol/L (.1) and in fasting gulls, they were also 1.2 mmol/L (.1). Similar results were found in a second experiment. These values are higher than our mean triglyceride values. However, this could be due to differences in extra mass in these gulls that was not present in our sample of loons.

In species with biparental care, triglyceride values have indicated that adults can maintain or recover (in the case of females) body mass throughout incubation. Alonso-Alvarez et al (2002) studied changes in body mass and plasma biochemistry during incubation in yellow-legged gulls (*Larus cachinnans*). Triglyceride values averaged 1.25 ( $\pm 0.13$ ) mmol/L for the first 10 days of incubation and 1.16 ( $\pm 0.14$ ) mmol/L during the last ten days of incubation. Female and male triglyceride values were not significantly different from each other and did not change significantly throughout incubation, which indicated stable lipid reserves in the sampled birds (since body fat is correlated with triglyceride values). Glycerol levels were not reported in this study.

At breeding season-level metabolic rates, metabolites have been shown to track fat stores better than body mass and activity levels. Jenni and Schilch (2001) studied changes in metabolite levels as they varied with changes in mass in reed warblers (*Acrocephalus scirpaceus*). Triglyceride levels were positively related to change in body mass and time of day, while  $\beta$ -hydroxy-butyrate plasma levels were negatively related to

these same parameters (Fig. 3). Therefore, levels of plasma  $\beta$ -hydroxy-butyrate and triglycerides can be used to estimate body mass change in birds only captured one time (Glycerol levels were not reported in this study). Even though both of these metabolites reflect change in body mass, triglycerides demonstrate changes in fat stores more closely, as they are directly related to fat deposition, unlike  $\beta$ -hydroxy-butyrate, which is related more to transitions from one state to the other. Thus, triglyceride levels are better predictors of changes in lipids stores than overall change in body mass. Body mass and activity level were not correlated with triglyceride levels, and so within the range of body masses in the study, stores of fat did not influence triglyceride levels, which indicates that heavier birds may use alternate energy forms for overnight fasting and rely less on the catabolism of lipids (thus their lower  $\beta$ -hydroxy-butyrate levels by morning).



**Figure 3. Figure From Jenni and Schilch (2001).** “Relationship between hourly change in body mass of reed warblers since early morning ( $\Delta$ MASS-B) and triglycerides (a) or  $\beta$ -hydroxy-butyrate levels (b). The metabolite values displayed have been standardized to 6 h after lights on according to the models.”

At low metabolic rates (like those experienced during the extended inactivity associated with incubation), triglyceride levels correlate positively with energetic condition. In 2010, Bauch et al. examined triglyceride, uric acid, and cholesterol levels in incubating common terns (*Sterna hirundo*). In this study, triglyceride levels were

measured during three different periods of the incubation (early, middle, and late) and two levels of breeding experience (experienced and inexperienced). Glycerol values were not examined in this study. In 2006, the highest triglyceride values were measured during the early incubation period and ranged from 1.00 mmol/ L (inexperienced breeders) to 1.26 mmol/L (experienced breeders). Regardless of experience level, birds in higher energetic condition (prior to incubation) exhibited higher triglyceride levels, and individuals in higher condition (experienced breeders) also exhibited higher levels than more inexperienced individuals. In 2007, there was more variation between triglyceride levels, but again the greatest variation was in the earliest part of incubation. The values in this year ranged from 1.10 mmol/L (inexperienced breeders) to 1.69 mmol/L (experienced breeders).

#### **1.14. SYNOPSIS**

In the two chapters that follow, I investigate the relationships between environmental characteristics and common loon occupancy, productivity, and physiological condition along the southern edge of the breeding range. I aimed to determine factors that influence distribution and understand the links between climate change and range edges. My overarching goal was to determine if climate change will impact loon demography and the location of the southern range edge through habitat preferences, changes in energetic state, and reproductive success on previously viable lakes.

The scope of my analysis took place on varying geographic scales, with narrowing focus. The largest occupation model in Chapter 2 included lakes across the United States portion of the historical breeding range (south to the maximum extent of

the Laurentide Ice Sheet). Reproductive success was analyzed within the Northeastern US across the region currently occupied by loons. Behavioral analysis encompassed a portion of lakes in Maine, New York, Vermont, and Massachusetts, where more detailed observations have been conducted. Finally, energetic measures were studied on a subset of loons sampled from lakes in New Hampshire, Western Maine, Massachusetts, Washington and Montana.

Our results from the large-scale occupancy model identified lake salinity, acidity, and sulfate levels as significant predictors. Similar factors drove loon presence/absence in New England (lake salinity and alkalinity) as well as a unique parameter, lake surface area. Loon productivity, on the other hand, was best predicted as either high or low using the size of both the lake and drainage basin. Lake surface area and is thus good predictors of both loon distribution and loon productivity, and are thus also likely to be useful in predicting range shifts in the future. These outcomes suggest that future range alteration for loons due to climate change is likely to be more sensitive to annual adult survival (which will influence breeding ground settlement patterns) than environmental factors encountered on the breeding grounds.

For our physiological examination of range contraction we used measures of triglycerides (as free glycerol was very low and showed little variation, as we would expect for fasting birds maintaining mass with relatively low to mid metabolic rates). Blood triglyceride concentrations suggest that the number of chicks, breeding latitude, and daily temperature are important predictors of loon energy expenditure. Specifically we found that: 1) loons with two chicks expend more energy than those with one, 2) loons near the southern range edge expend more energy to produce a given brood size



than those nearer the range center and, 3) birds breeding in warmer temperatures expend more energy than those in cooler temperatures (controlling for year, territory type, and calendar date, free glycerol levels, size-corrected body mass, and longitude). Species-specific physiological thresholds of temperature, are known to limit the distribution of a wide variety of organisms (Nickerson et al. 1988, Walther et al. 2002, Pörtner 2002), and it is reasonable therefore to assume that we can detect initial differences in triglyceride or glycerol values under thermal conditions that are less extreme. This initial variance could then potentially act as a harbinger of larger scale population changes.

Together, the findings from both of my chapters suggest that there are scalar and biological differences in detectability of factors that will cause range contraction under climate conditions. Clearly, occupancy, productivity, and physiological state were best predicted by different environmental characteristics. Of the predictors related to loon distribution, only  $\text{SO}_4$  was predicted to be influenced by climate change. Our large-scale analysis found that human impacts will have the greatest initial impact on distribution and that of the predictors related to productivity, none were predicted to change with climate change. My model did not include all possible factors that could influence loon presence/ absence or productivity. For example, I did not test underlying bedrock or other large geographic features of the landscape which may have also helped explained patterns in limnology and loon distribution. I also did not test the social and behavioral factors that might limit the dispersal of loons. The larger scale models are helpful for identifying possible trends in occupation across wide spatial scales, which is the scale of climate change that may cause shifts in loon distributions.

With my physiology model, I detected influences on energetic demand (which could manifest themselves as loss in productivity) and found these factors to be tied to temperature and to warming trends. The physiology model was able to detect factors related to climate change because of the influence of temperature on metabolic rate. The physiological model is perhaps most informative model in terms of understanding of climate change as it captures the physical, behavioral, and environmental forces acting on a given individual.

**CHAPTER 2**

**MACHINE LEARNING TECHNIQUES: A TOOL FOR UNDERSTANDING  
COMMON LOON (*GAVIA IMMER*) BIOGEOGRAPHY AND  
PRODUCTIVITY IN AN ERA OF CLIMATE CHANGE**

**2.1. ABSTRACT**

Climate change has the potential to shift and restrict ranges for a suite of species. The birds of the boreal ecosystem, like the common loon (*Gavia immer*), may be particularly at risk given the changes predicted for this biome. Current range models for this iconic water bird predict that large sections of the United States may lose the loon in the next 100 years, but these models are based on habitat correlations and not the demographic mechanisms that will actually produce the change. The primary goal of our research was to understand the factors contributing to the vulnerability of loons to climatic change at multiple scales. We applied a recursive partitioning technique to analyze loon presence/absence in 288 lakes across the southern edge of their North American distribution using 112 abiotic and landscape-level factors. The resulting binary tree (“decision tree”) classified lakes into groups based on the probability of loon presence, while maximizing homogeneity within the resultant two nodes. The most significant splits in the cross-validated tree were created using lake salinity, acidity, and sulfate levels. We employed similar methods to compare loon occupancy and seasonal fecundity at a smaller scale (New England) to elucidate potential demographic mechanisms of loon persistence. Results from twenty potential predictors suggest that processes similar to the continental model are also driving loon presence/absence in New

England (lake salinity, alkalinity, and lake surface area). Loon productivity, on the other hand, was best predicted as either high or low using the size of both the lake and drainage basin. Lake surface area and characteristics of the drainage basin are thus good predictors of both loon distribution and loon productivity, and are thus also likely to be useful in predicting range shifts in the future. As few (if any) of the predictors of productivity in the best decision trees are likely to change dramatically with climate, these outcomes suggest that future range alteration for loons due to climate change is likely to be more sensitive to annual adult survival (which will influence breeding ground settlement patterns) than environmental factors encountered on the breeding grounds.

## **2.2. INTRODUCTION**

### **2.2.1. Climate Change and Freshwater Communities**

Climate change is predicted to cause numerous effects on the global environment in the coming century (IPCC, 2007). Among the projected changes in the United States are increases in mean surface air temperature, an increase in the concentration of carbon dioxide in the atmosphere, increases in concentrations of other greenhouse gases (e.g. methane, nitrous oxide, tropospheric ozone), warming of mean sea-level temperature, and a rise in global mean sea-level (Watkinson et al. 2004). Additionally, predicted changes in the seasonality of precipitation could greatly impact the structure of existing ecosystems (Rodenhouse et al. 2007). In New England, precipitation is predicted to increase, drought periods are expected to extend, and air temperature is projected to increase, and these changes will likely alter freshwater ecosystems (Magnuson et al. 1997, Poff 2002, Jacobson et al. 2009) and local hydrologic regimes (IPCC 2007).

These anticipated abiotic transitions will undoubtedly affect the distribution and characteristics of the biota, as well. Certainly, changes in air and water temperature can alter the production, abundance, and distributions of aquatic organisms (Jacobson et al. 2009). Climate change has been shown to impact avian distributions through range shifts (Hitch and Leberg 2007), contractions (Virkkala et al. 2008), and expansions (Martinez-Morales et al. 2010). Accurately predicting changes in the distributions of these or other organisms using abiotic drivers, however, has proved elusive (Davis et al. 1998a, 1998b, Thomas and Lennon 1999, Beale et al. 2008, Williams and Jackson 2012).

Determining the controls on a species' distribution can vary from the obvious (e.g. resource specialists) to the complex due to the interplay of competing ecological and evolutionary dynamics (Gaston 2003). Studying species on the edge of their range, however, helps us understand controls on organismal distributions and necessitates the consideration of adaptive evolution and demographic processes (Holt and Keitt 2005, Holt et al. 2005). Many existing models predicting climate-induced changes in animal distributions are based on bioclimatic envelopes (contemporary correlations between a species' distribution and other taxa or abiotic conditions) and thus are limited in their ability to predict changes accurately (Thuiller 2003, Heikkinen et al. 2006). In a majority of cases, distributions may be explained better by biotic interactions, limits to dispersal, adaptive evolution, or other alterations of basic demographic parameters (Davis et al. 1998a, Thomas et al. 2001, Heikkinen et al. 2006).

One of the largest flaws of bioclimatic envelope modeling is the assumption that current correlations with distribution will hold under future conditions. This assumption may be safer when the environmental correlations are tied directly to demographic

processes (Chase et al. 2005, Seavy et al. 2008) or average individual condition, rather than tied indirectly to the distributional patterns that result from these lower order processes. Demographically explicit models, however, are data intensive and infeasible for modeling most continental-scale distributions. Here we suggest a hybrid approach, where we first develop an envelope model for the southern breeding distribution of the lake-residing common loon, *Gavia immer*, in North America, and then we validate this model by comparing the best indicators of range edge at the continental scale to those identified by a smaller-scale, demographically explicit model (chick production across New England). Additionally, we use hypothesis testing to determine how climate change is most likely to alter future distributions, by A) identifying a set of environmental variables that have the potential to change over the next century and then B) testing the ability of these variables to explain the current loon distribution. While this will not identify non-linear range responses to changes in these variables outside the current observed range of variation, it will allow us to determine whether candidate predictors of the current range edge are also candidates for change themselves. This coupled demographic validation and hypothesis-driven approach can identify drivers of demographic change at continental scales, even for ecological futures without a direct contemporary analog. For the common loon in particular, this represents a discrete step forward in identifying the likelihood of range change.

### **2.2.2. Machine Learning: Using Decision Trees and Random Forests to Determine Variable Importance**

We used a machine-learning approach as it presents some distinct advantages for predicting range limit drivers over the more traditional general linear or generalized

linear models used in bioclimatic envelope models. Classification and regression-tree analyses (or decision trees) are becoming a more widely used method for modeling species distribution due to their ease of interpretation and ability to simultaneously process various explanatory variable types (e.g. categorical, numeric, and continuous). Decision trees are most noteworthy in their ability to investigate data with correlated and complex relationships (De'ath and Fabricius 2000). While more traditional methods of modeling a species' presence versus absence (e.g. logistic regression) quickly outgrow the ability to handle multiple predictors and their interactions, classification trees consider each predictor as a potential variable for splitting the data (O'Connor and Wagner 2004). Decision trees also describe a series of nested, hierarchical thresholds, an approach that may reflect the actual physiological and behavioral processes that determine range edges.

In decision trees, the entire dataset represents what is called the "root node". Each subsequent split is referred to as a "node", and the final nodes (after which there is no further partitioning of data) are referred to as "leaves" or "terminal nodes". The candidate predictor variable that explains the greatest deviance in the response variable produces the first node. Using a recursive partitioning method, data are then split with the remaining explanatory variables to maximize heterogeneity between the left and right branches and homogeneity within each resultant branch (and decrease the Gini index, which is a measure of impurity; further explained below) (Crawley 2007).

Despite their merits, decision trees have a tendency to over-fit the data and can be unstable, whereby a small change in the data can result in a large change in the outcome of the tree (De'ath and Fabricius 2000). This problem can be avoided by cross-

validating the tree using a cost-complexity measure (known as “pruning” the tree) to decrease the misclassification rate, and both problems can be avoided by comparing decision-tree results to those produced by random forests, a resampling technique that addresses the instability in machine learning. Random forests can also assess the strength of individual variables by comparing their performance across multiple trees constructed from subsets of the data through the use of a composite Gini index, an impurity criterion (Cutler et al. 2007). The Gini index is higher for the parent nodes than the descendent nodes, thus high summed Gini indexes (the Gini Importance Measure) across the random forest represent variables that occurred more commonly in higher nodes. Further, random forests are not prone to over-fitting like individual decision trees can be.

### **2.2.3. General Approach**

We included seven variables in our analysis of the southern edge of the loon breeding range that were previously reported as important in smaller scale studies and several dozen additional variables that we hypothesized might be important on a continental scale. Previously reported predictors of loon distributions or reproduction included lake depth and lake surface area (Alvo et al. 1988), water clarity (Barr 1973, Gostomski and Evers 1998, Lathrop et al. 1999, Evers et al. 2010), water surface temperature (Blair 1992), pH (Alvo et al. 1988, Parker 1988, McNicol et al. 1995, but see Badzinski and Timmermans 2006), conductivity (Alvo et al. 1988, Blair 1992), and dissolved organic carbon (Badzinski and Timmermans 2006). We collected values for all of our candidate variables from sites across the current southern breeding limit in North America (including parts of Washington, Idaho, Montana, Minnesota, Wisconsin, Michigan, New York, Maine, Vermont, New Hampshire, and Massachusetts; Evers et al.



2010). If any of these metrics influence demographic processes along this range edge, they are potentially more informative for predicting future loon distributions than values from range-wide envelopes, as range contraction or expansion occurs presumably as a function of conditions along edges. This more narrow spatial focus should increase the chances that we identify patterns important for predicting changes in the southern limit of distribution.

We used machine learning techniques to model (1) loon presence/absence on a continental scale as a function of landscape and lake-level predictors and (2) productivity on a regional scale to determine if similar variables influenced distribution and productivity. We also discuss the potential of highly ranked model predictors to change with climate over the next century. The development of models that link species' ranges to ecological and demographic processes is necessary to predict changes in organism distributions under changing climates and rapid landscape evolution (Holt and Keitt 2005). Though our results are specific to loons, this paired continental and regional comparison, underpinned by specific climate change hypotheses, is applicable to any species on any scale and may be an improvement upon traditional envelope modeling.

## **2.3 METHODS**

### **2.3.1. Methods Overview**

We constructed a continental-scale decision tree of the environmental characteristics driving the common loon southern boundary in North America. To validate the demographic underpinning of this tree, we subsequently compared the results of this model to a decision tree predicting the productivity of loons in a long-term demographic study across the New England region (1987 – 2010). As the productivity

model was created using fewer predictors than the continental model, we validated this model with a presence/absence model using a reduced number of predictors, as well. All decision tree analyses were substantiated using a random forest approach..

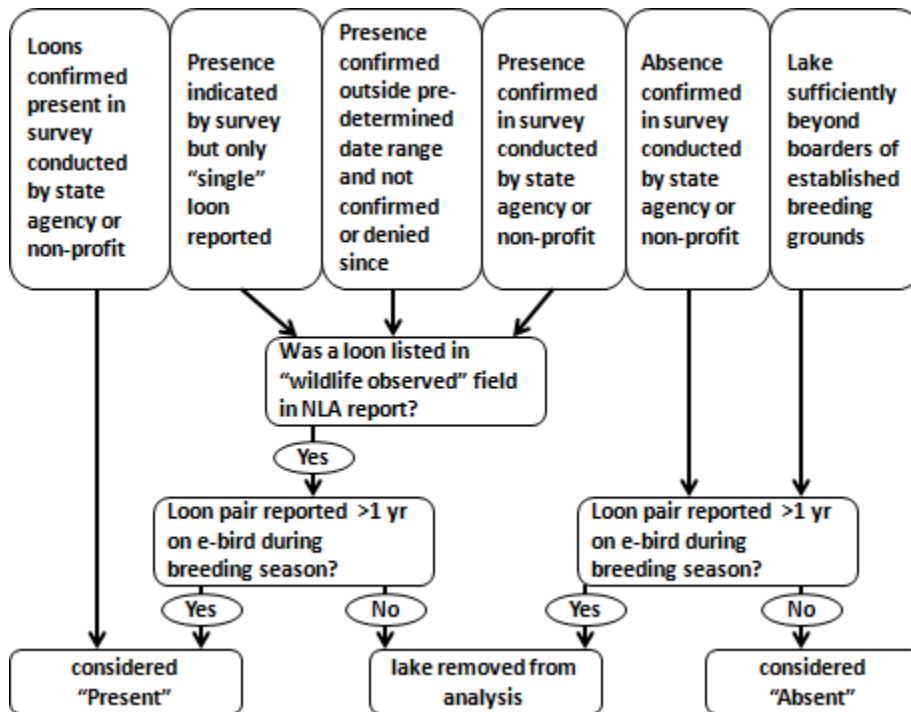
### **2.3.2. Continental-scale Range Descriptors**

For the continental-scale decision tree, we used data collected by the Environmental Protection Agency for the 2007 National Lakes Assessment (NLA) Report ([http://water.epa.gov/type/lakes/lakessurvey\\_index.cfm](http://water.epa.gov/type/lakes/lakessurvey_index.cfm)). The goals of the NLA study were to assess the biological health of lakes of the United States and to determine baseline measures for future studies. The study included 909 lakes selected using a probability-based design. Lakes smaller than 4 hectares were not included in the analysis, which coincidentally corresponds with the size of the smallest lake reported to support chick production by common loons (4.05 hectares; McIntyre 1994). We chose lake data from this study due to its spatial scale, the consistency of collection (all data collected within the summer of 2007), the precise data collection procedures, and the large number of parameters measured at each lake.

We collected loon presence/absence data for 288 NLA lakes from state agencies and non-governmental organizations that have gathered monitoring information within 5 years of 2007 (Table 2). Loons were deemed “present” or “absent” on a given lake using a consistent hierarchical classification process (Fig. 4). Any lakes that could not be confidently determined as having loon “presence” or “absence” under these criteria were excluded from the analysis (final lakes included in analysis: Fig. 5).

**Table 2. Data Sources.** Organizations that contributed common loon (*Gavia immer*) presence/absence data to this study (data collected within five years of 2007).

State	Organization(s)
Maine	Maine Audubon, Biodiversity Research Institute
Massachusetts	MassWildlife, Massachusetts Division of Conservation and Recreation
Michigan	Michigan Natural Features Inventory, Biotics 4- Michigan's Natural Heritage Database; Biodiversity Research Institute, Lake Superior State University
Minnesota	Northland College
Montana	Montana Common Loon Working Group, Montana Fish, Wildlife & Parks, ND: Northern Prairie Wildlife Research Center
New Hampshire	Loon Preservation Committee; Idaho: Idaho Fish and Wildlife Information System
New York	Biodiversity Research Institute's Adirondack Center for Loon Conservation, Wildlife Conservation Society's Adirondack Program
Vermont	Vermont Center for Ecostudies
Washington	Northeast Washington Common Loon Observation Project Daniel and Ginger Poleschook (Biodiversity Research Institute)
Wisconsin	LoonWatch, Sigurd Olson Environmental Institute, Northland College
Wyoming	Wyoming Game and Fish Department., Loon Lake Loon Association, Wyoming Game and Fish Department



**Figure 4. Determining Loon Presence/Absence.** Hierarchical classification process for determining common loon presence, absence, or exclusion from analysis for lakes in the National Lakes Assessment Database (2007), 2005-2009.



**Figure 5. Lakes Used In Analysis.** Location of the maximum extent of the Laurentide ice sheet (blue line) and locations of lakes (green = present, white = absent; n = 288) included in nationwide analysis of variables thought to influence common loon distribution across their southern breeding range edge, 2005-2009.

To identify the environmental characteristics that best predict the current southern range boundary of common loons, we gathered information from the NLA dataset for U.S. lakes within a belt that varied in width across the country, but included the areas once covered by the Laurentide ice sheet which began retreating between 18 and 13 ka (Fig. 6; Dyke and Prest, 1987). Lakes created during the Late Wisconsinian and Holocene times are more similar to each other than to those outside the range of this ice sheet (Dyke and Prest 1987), and there is historical evidence that the breeding range of the common loon included lakes south to this glacial boundary within the last millennium (Evers et al. 2010). We did not include lakes that currently support loons within small disjunct populations in the mountainous west south of the continuous range (e.g.

Wyoming), because our primary goal was to predict the continuous southern range boundary, and we suspect different settlement processes are at play in this region (Evers, 2010). We also excluded lakes from the plains states (ND, SD, and Western MT), because there is no evidence that these lakes were ever occupied by loons within the last millennium (Evers et al. 2010). This exclusion only eliminated one currently occupied breeding lake from this entire region.



**Figure 6. Map For Determining Lake Inclusion.** Map demonstrating inclusion process for lakes in nation-wide presence/absence analysis, 2005-2009. Numbers represent a “region” variable included to account for regional differences in factors predicting presence/absence. The “x’s” in WY and ND represent small and isolated population of loons in this region and thus these regions were excluded from analysis due to our goal of predicting factors effecting range edge along a continuous area. The blue line represents the maximum extent of the Laurentide ice sheet, which began retreating between 18 and 13 ka (Dyke and Prest, 1987).

**Table 3. Variables in National Presence/Absence Analysis.** Variables included in nation-wide analysis of common loon presence/absence along their southern range edge in the United States, 2005-2009. (\* signifies variables combined to make new category; ^ scored as: None/Low/Moderate/Heavy ; \*\* scored as Low=1, Medium=3, High=5)

<b>Watershed Landuse Metrics</b>	
Variable name:	Percent of Watershed as:
PCT_OPENH20_BSN	Open water
PCT_BARREN_BSN	Barren land
PCT_GRASS_BSN	Grassland/herbaceous
PCT_SHRUBLAND_BSN	Shrub/scrub
BSN_PCT_SHRB_GRS	*Non-forest/crops (shrub/scrub, grassland/herbaceous)
PCT_PASTURE_BSN	Pasture/hay
PCT_CROPS_BSN	Cultivated crops
BSN_PCT_FARM	*Farm (pasture/hay and cultivated crops)
PCT_DEVHIGH_BSN	High intensity development
PCT_DEVLOW_BSN	Low intensity development
PCT_DEVMED_BSN	Medium intensity development
PCT_DEVOPEN_BSN	Open space development
BSN_PCT_DEVEL	*Developed (high intensity, low intensity, medium intensity, open space)
PCT_DECID_BSN	Deciduous forest
PCT_MIXED_BSN	Mixed forest
PCT_CONIF_BSN	Evergreen forest
BSN_PCT_FOREST	*Forested (evergreen, deciduous, mixed)
PCT_WDYWET_BSN	Woody wetland
PCT_EMHERBWET_BSN	Emergent herbaceous wetland
BSN_PCT_WETLD	*Wetland (woody wetland, emergent herbaceous wetland)
<b>Lake Buffer Landuse Metrics</b>	
Variable name:	Percentage of buffer as:
PCT_BARREN_BUFR_CONV	Barren land
PCT_CONIF_BUFR_CONV	Evergreen forest
PCT_DECID_BUFR_CONV	Deciduous forest
PCT_MIXED_BUFR_CONV	Mixed forest
BUFR_PCT_FOREST_CONV	*Forest (mixed, deciduous and evergreen)
PCT_DEVHIGH_BUFR_CONV	High intensity development
PCT_DEVLOW_BUFR_CONV	Low intensity development
PCT_DEVMED_BUFR_CONV	Medium intensity development
PCT_DEVOPEN_BUFR_CONV	Open space development

**Table 3. Continued**

**Lake Buffer Landuse Metrics**

Variable name:	
BUFR_PCT_DEVEL_CONV	*Developed (high intensity, low intensity, medium intensity, open space)
PCT_GRASS_BUFR_CONV	Grassland/herbaceous
PCT_SHRUBLAND_BUFR_CONV	Shrub/scrub
BUFR_PCT_SHRB_GRS_CONV	*Non-forest/crops (shrub/scrub, grassland/herbaceous)
PCT_CROPS_BUFR_CONV	Cultivated crops
PCT_PASTURE_BUFR_CONV	Pasture/hay
BUFR_PCT_FARM_CONV	*Farm (pasture/hay, cultivated crops)
PCT_EMHERBWET_BUFR_CONV	Emergent herbaceous wetland
PCT_WDYWET_BUFR_CONV	Woody wetland
BUFR_PCT_WETLD_CONV	*Wetland (woody wetland, emergent herbaceous wetland)

**Lake Physical Characteristics**

Variable name:	Variable Description:
DEPTHMAX	Maximum observed lake depth (m)
ELEV_PT	Site elevation (meters) from National Elevation Dataset
LAKEAREA	Lake polygon area (km <sup>2</sup> ) from National Elevation Dataset
LAKEPERIM	Lake polygon perimeter (km) from NHD
LEVEL_CHANGES	Elevation change (m) of lake level
MACRY_FLOAT	Emergent/floating coverage (% lake area)
MACRY_SUBMERGED	Submergent/floating coverage (% lake area)
PCT_EMRG_SUB_VEG	*Percent of submergent/floating, emergent/floating coverage
SLD	Shoreline devel't index (LAKEPERIM/(2*sqrt(LAKEAREA*pi)))
LONG	Longitude
BASINAREA_HA	Watershed area
REGION	Region 1: NJ, VT, NH, NY, NJ, PA, RI, CT, MA; Region 2: MI, OH, IL, IN, eastern WI; Region 3: Western WI, IO, MN; Region 4: WA, MT



**Table 3. Continued****Lake Chemical Properties**

Variable name:	Variable Description:
ANC	Gran ANC (ueq/L), Acid Neutralization Capacity (ANC)
CL	Chloride (ueq/L)
COLOR	Color (PCU)
COND	Conductivity (uS/cm @ 25 C)
CYANDENS	Cyanophyta density (#/cm <sup>2</sup> )
DO_FIELD	Field dissolved oxygen (mg/L)
DOC	Dissolved organic carbon (mg/L)
H	H <sup>+</sup> from PH_LAB (ueq/L)
K	Potassium (ueq/L)
MCYST_TL_UGL	Total microcystin concentration (ug/L)
MG	Magnesium (ueq/L)
NA	Sodium (ueq/L)
NH4	Ammonium (ueq/L)
NO3	Nitrate (ueq/L)
NTL	Total nitrogen (ug/L)
OH	Hydroxide from PH_LAB (ueq/L)
PH_FIELD	Field pH from Profile DO data (pH measured at first non-zero depth unless only depth was zero)
PTL	Total phosphorus (ug/L)
SIO2	Silica (mg/L SiO <sub>2</sub> )
SO4	Sulfate (ueq/L)
TEMP_FIELD	Field water temperature (oC)
TURB	Turbidity (NTU)

**Lake impacts and disturbances**

Variable name:	Variable Description:
AGR_CROPLAND	^Agricultural cropland disturbances obs'd ^Agricultural feedlot disturbances obs'd
AGR_FEEDLOT	
AGR_LIVESTOCK	^Agricultural livestock disturbances obs'd
AGR_ORCHARDS	^Agricultural orchards disturbances obs'd
AGR_PASTURE	^Agricultural pasture disturbances obs'd
AGR_POULTRY	^Agricultural poultry disturbances obs'd
AGR_WITHDRAWL	Agricultural water withdrawal
AGR_IMPACT	*Summed agricultural stressors
IND_SCORE	**Summed industrial stressor score
MAN_SCORE	**Summed lake management stressor score



**Table 3. Continued**

**Lake impacts and disturbances**

Variable name:	Variable Description:
REC_FILMS	^Recreational surface films, scums, slicks disturbances obs'd
REC_MARINAS	^Recreational marinas disturbances obs'd
REC_PARKS	^Recreational parks disturbances obs'd
REC_PRIMITIVE	^Recreational primitive parks, camping disturbances obs'd
REC_RESORTS	^Recreational resorts disturbances obs'd
REC_TRAILS	^Recreational hiking trails disturbances observed
REC_TRASH	^Recreational trash/litter disturbances obs'd
REC_IMPACT	*Summed recreational stressors
RES_BRIDGES	^Recreational bridges/causeways disturbances observed
RES_CONSTRUCTION	^Recreational construction disturbances obs'd
RES_DUMPING	^Residential dumping disturbances obs'd
RES_LAWNS	^Residential maintained lawns disturbances obs'd
RES_PIPES	^Residential pipes, drains disturbances obs'd
RES_RESIDENCES	^Residential residences disturbances obs'd
RES_ROADS	^Residential roads disturbances obs'd
RES_SEWAGE	^Residential sewage treatment disturbances obs'd
RES_IMPACT	*Summed residential stressors

**Shoreline characteristics**

Variable name:	Percentage of shoreline:
RCH_AGRICULTURE	agriculture
RCH_BARE_GROUND	bare ground
RCH_FOREST	forest
RCH_GRASS	grass
RCH_SHRUB	shrub
RCH_WETLAND	wetland
RCH_DEVELOPMENT	development (Res & Urban)
RCH_SHOREMODS	modified (docks, riprap)
RCH_ALTERED	*human modification (development, modified)

We compared the explanatory power of 112 lake characteristics, which we characterized into six general categories: watershed land-use metrics, lake buffer land-use metrics, lake physical characteristics, lake chemical properties, lake impacts and disturbances, and shoreline characteristics (complete list: Table 7). We removed one lake from consideration because of NLA data that were significantly outside the range of all other lakes (Grubb's test for one outlier,  $p < 10^{-16}$ ). We also included two variables to allow differential range determination by region (longitude and a categorical variable for the four glacial lobes identified in Figure 4). To validate this approach for identifying regional differences, we additionally constructed a decision tree for New England using the same predictors from our continental model. The results from this tree agreed with those from the continental model; therefore, we do not include further explanation of that model in this chapter.

When creating the continental classification tree, we set the minimum number of observations in a node to 30 before each split could be attempted and required the resulting split to reduce the overall lack of fit by a cost complexity factor of 0.001. The full tree explaining loon presence and absence was cross-validated ten times (using the "xval" command within the "rpart" statement of R), and we then used the complexity parameter to prune each tree to a size that minimized cross-validation error (Breiman et al. 1984). We validated the pruned tree by running a random forest of 1000 trees from the original dataset to assess the stability of our results. The "out-of-bag" (OOB) error rate did not indicate that the random forest would have benefited from the addition of more trees. Because there is no currently accepted standard for the number of predictors that should be attempted at each node, we varied our values from 1 to 112 (in increments

of 10) and used the number of predictors that yielded the lowest OOB error rate (“mtry” = 50; OOB error rate = 9.98%). Lastly, we created variable importance plots for all predictor variables using both the decrease in mean Gini index value and the mean decrease in model accuracy after the removal of each variable (calculated as the normalized difference between the classification accuracy of the number of correctly classified samples before the removal of a given variable from the number of correctly classified samples after permutation, divided by the number of OOB samples for that tree). This value was calculated for each of the 1000 trees in the random forest and its average thus corresponds to the importance of a given variable in a model. We then conducted partial dependence plots to explore the importance of top-ranked variables within the random forest models.

### **2.3.3. Regional-scale Range Descriptors**

The majority of lakes for which we had detailed demographic information were not contained within the NLA database. We therefore constructed a decision tree using the lakes of VT, NH, NY, and ME, but only considered the 20 variables that were available for our lakes with demographic information as well (Table 4). These lake data were compiled from the Environmental Protection Agency Wildlife Database Search Engine (see “WDSE” for further information below).

**Table 4. Variables in New England Presence/Absence Analysis.** Variables included in the analysis of common loon presence/absence along their southern breeding-range edge in New England states, United States, 2005-2009.

<b>Variable name</b>	<b>Variable Description</b>
BASINAREA_HA	Watershed area
ELEV_PT	Site elevation (meters) from National Elevation Dataset
DEPTHMAX	Maximum observed lake depth (m)
LAKEAREA	Lake polygon area (km <sup>2</sup> ) from National Elevation Dataset
LAKEPERIM	Lake polygon perimeter (km) from NHD
CHLA	Chloride (ueq/L)
PH_FIELD	Total phosphorus (ug/L)
ANC	Gran ANC (ueq/L), Acid Neutralization Capacity (ANC)
TURB	Turbidity (NTU)
CL	Chloride (ueq/L)
NO3	Nitrate (ueq/L)
SO4	Sulfate (ueq/L)
CA	Calcium (ueq/L)
MG	Magnesium (ueq/L)
NA	Sodium (ueq/L)
K	Potassium (ueq/L)
COLOR	Color (PCU)
COND	Conductivity (uS/cm @ 25 C)
DO_FIELD	Field dissolved oxygen (mg/L)
PTL	Total phosphorus (ug/L)

#### **2.3.4. Regional Productivity Descriptors**

We then constructed a decision tree to describe loon productivity across the Northeastern United States. The Biodiversity Research Institute (BRI) has been collecting data on loons throughout this region since 1987. The most continuous and rigorous data are from the mountains of western Maine, beginning with work on 4 lakes (12 loon territories) in 1993 (Dodge Lake, Quimby Lake, Rangeley Lake, and Round Lake). Today, data are collected on 179 territories over 38 lakes in western Maine. Additional data were included from New Hampshire (Loon Preservation Society), Vermont (Vermont Center for Ecostudies), Massachusetts (MassWildlife, Massachusetts

Division of Conservation and Recreation), and New York (Biodiversity Research Institute's Adirondack Center for Loon Conservation and The Wildlife Conservation Society's Adirondack Program). Information from these sources was used to construct our New England productivity decision tree.

We modeled the number of chicks surviving per pair (after four weeks of age) using environmental lake characteristics found in the Environmental Protection Agency Wildlife Database Search Engine (WDSE: <http://oaspub.epa.gov/aed/wildlife.search>). We included 20 candidate variables from the WDSE (Table 5) that were measured consistently across all lakes with productivity information. Loon productivity and lake characteristics (when there were multiple entries for either) were averaged over each decade for each lake (e.g. 1980's, 1990's, 2000's). Averaging data by decade allowed us to examine lakes on a fine spatial scale while correcting for individual loon-intrinsic or seasonal variance in productivity or lake characteristics. The productivity means were calculated across all territories within a lake, resulting in a continuous response variable of average number of chicks per pair per lake for the decade, thus averaging out the differences in productivity caused by either different individuals on different territories or different territory holders across years. Tree construction operated similarly to the previous models. We ran cross-validation ten times and plotted the cross-validation error. We plotted the mean squared error (MSE) and total decrease in node impurity (from splitting on a given variable) and our regression trees were substantiated with this random forest model. We validated both of these models with random forests in the same way we did our continental scale model.

**Table 5. Variables in New England Productivity Analysis.** Variables included in analysis of common loon productivity along their southern breeding-range edge in New England states, United States, 1980-2010.

<b>Variable Name</b>	<b>Variable measurement</b>
Loon Decade	Decade loon captured
watershed area acres	Watershed area, acres
Lake surface area acres	Lake surface area, acres
max lake depth m	Maximum lake depth, meters
elevation m	Elevation, meters
shoreline length m	Shoreline length, meters
ANC	Acid neutralizing capacity, mg/L
calcium	Calcium, mg/L
chlorophylla	Chlorophyll A, ug/L
chloride	Chloride, mg/L
color	Color, SPU
DOX	Dissolved Oxygen, mg/L
MAGNESIUM	Magnesium, mg/L
NITRATE	Nitrate, mg/L
PH	pH, pH units
PHOSPHORUS	Phosphorus, mg/L
POTASSIUM	Potassium, mg/L
SECCHI	Secchi, meters
SODIUM	Sodium, mg/L
SCONDUCT	Specific conductance, uS/cm
SULFATE	Sulfate, mg/L
TEMP	Temperature, degrees Celcius
TURBIDITY	Turbidity, NTU

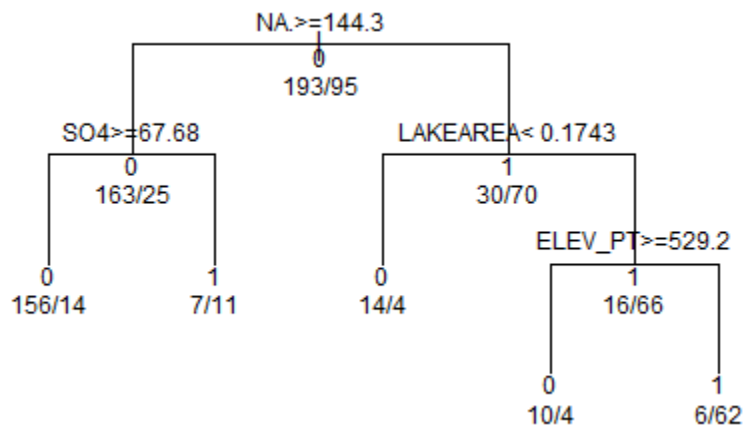
We created all of the classification and regression trees using R version 2.14.1, Package *rpart* version 3.1-50 (Therneau et al. 2012). We created the random forest using R version 2.14.1, Package *randomForest* version 4.6-6 (Liaw and Wiener 2012).

## 2.4. RESULTS

### 2.4.1. Continental-scale Range Descriptors

The pruned, continental-scale decision tree used five of the 112 potential variables across seven terminal nodes and had a residual mean deviance of 0.12 (Fig. 7). The

retained variables included lake water Na<sup>+</sup> ion levels (ueq/L), lake surface area, SO<sub>4</sub> (ueq/L) concentration, and lake elevation above sea level. For lakes with Na<sup>+</sup> ion levels greater than or equal to 144.3 ueq/L, loon presence was predicted positively by lower SO<sub>4</sub> levels (threshold  $\geq 67.68$  ueq/L) and negatively by higher SO<sub>4</sub> concentrations in the lake. For lakes with Na<sup>+</sup> of  $< 144.3$  ueq/L, loons were absent on small lakes (threshold = 17.43 hectares), but in larger lakes loons were present on lakes at elevations greater than 529.2 meters above sea level and absent at lower elevation lakes.



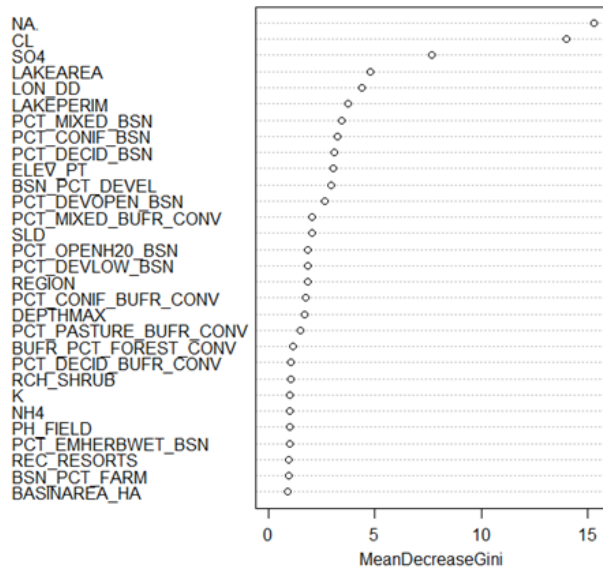
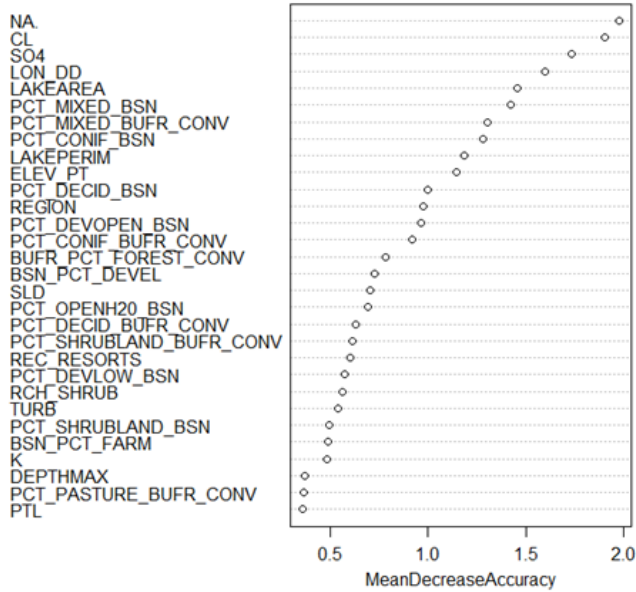
**Figure 7. United States Classification Tree.** Pruned classification tree for common loon presence/absence along the southern range edge, 2005-2009. Predicted values for splitting decision (i.e. thresholds) and number of cases are presented at each node (absences / presences). Predicted values of occupancy (0= absent, 1 = present) and number of cases are presented at each terminal node. Each node (i.e. split) is shown as an inequality. If the inequality is true, follow the left branch; if not proceed to the right branch.

Mean decreases in model accuracy and Gini indices for variables from each of the random forest permutations (Fig. 8) largely agreed with our full, pruned tree, ranking Na<sup>+</sup> and SO<sub>4</sub> concentrations as the first and third most important variables, respectively. Lake surface area also ranked high in importance for both the full tree and random forest

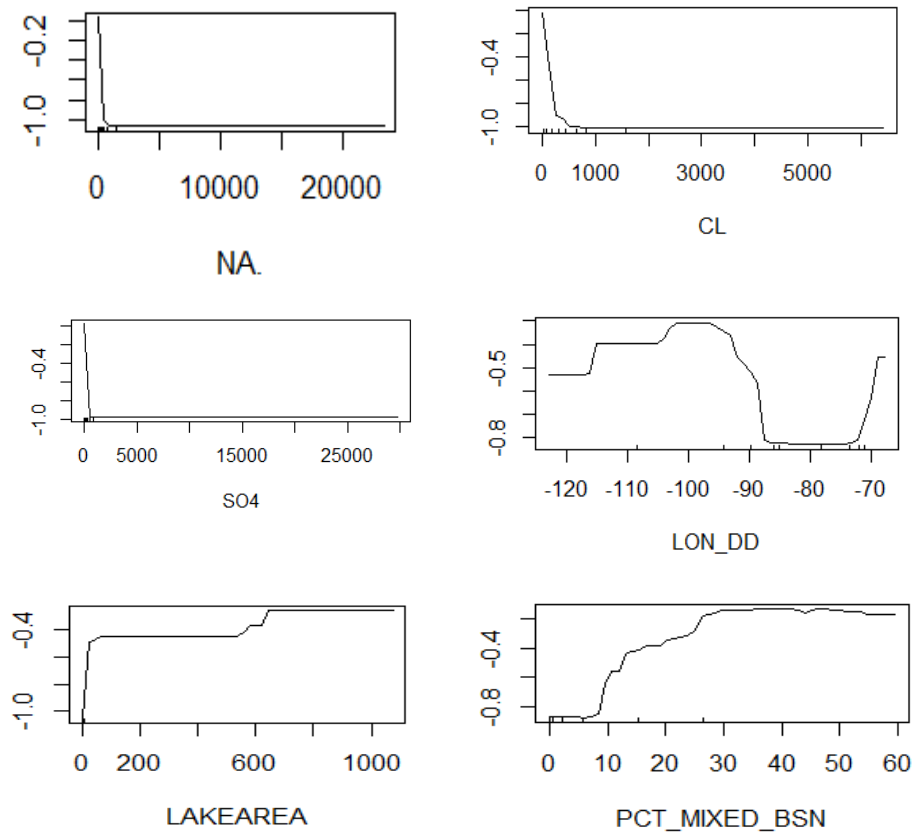
(ranked fourth and fifth by the Gini indices and mean decreases in accuracy respectively). Chloride ion concentration was the second most important predictor in the random forest, although it did not appear in our final classification tree. Scree plots of our two importance rankings suggest either five (Gini Indices) or six (Model Accuracy) important variables overall, and include regional differences (longitude) and the percent of mixed deciduous and coniferous forest in the drainage basin as important predictors along with lake chemistry and size. Lake elevation was the tenth highest ranked, but was not as strongly supported by the random forest models as the other top-ranking variables identified by the continental classification tree (and likely correlates with forest cover in the drainage basin).

The partial dependence plots of the six highest ranked predictors each showed a variety of threshold shapes for loon presence averaged over the effects of all other variables (Fig. 9). At lower values of sulfate ( $\text{SO}_4$ ), chloride ( $\text{Cl}^-$ ), and sodium ( $\text{Na}^+$ ), the logit of probability of presence was high and then it decreased sharply (Fig. 11). An increase in longitude (moving east) corresponded with an increase in the logit probability of loon presence until  $-94^\circ$  longitude, after which the logit probability decreased steeply until  $-72^\circ$  longitude. The logit probability of loon presence increased rapidly across small lakes, and then leveled out after lakes larger than 100 hectares. The probability of loon presence was low for values of mixed forest cover in the watershed until about 9%, after which it increased rapidly.





**Figure 8. Random Forest Analysis For United States.** Mean decrease in accuracy and mean decrease in Gini Index of first 33 variables for random forest model of presence/absence across the continental United States using 112 predictive variables, 2005-2009. Variables higher on the list are more important to explaining the response variable than those lower on the list. To determine the mean decrease in accuracy, the prediction error on OOB data is subtracted from the OOB error after permuting each predictor variable. These differences are averaged over the trees (normalized by standard deviation of differences). The decrease in node impurity is the total decrease in impurity from splitting on a given variable. To determine the mean decrease in Gini Index (another impurity criterion), a score is assigned to a variable each time is used as one of the primary splits in a tree. Gini Indexes are higher for the parent nodes than the descendent nodes, thus high summed Gini indexes (the Gini Importance Measure) across the random forest represent variables that occurred more commonly in higher nodes.

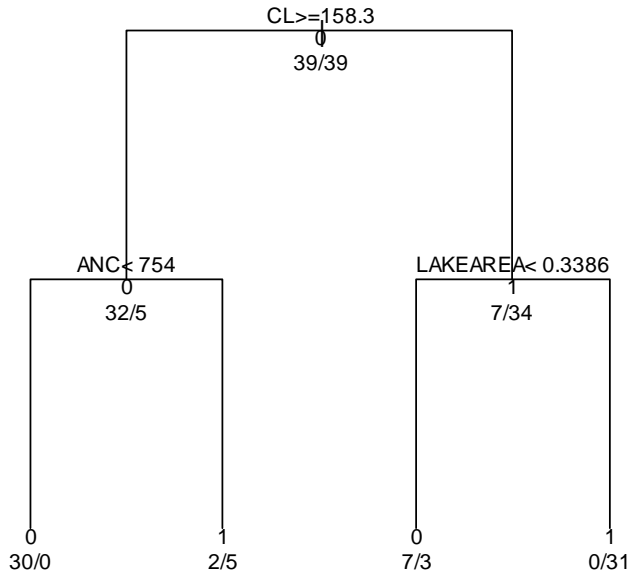


**Figure 9. Dependence Plots for United States Analysis.** Partial dependence plots give a graphical representation of the marginal effect of a variable on the probability of presence or absence, 2005-2009. These are partial dependence plots for the top six most important variables for a continental analysis of common loon distribution along their southern range edge in the United States.

#### 2.4.2. Regional-scale Range Descriptors

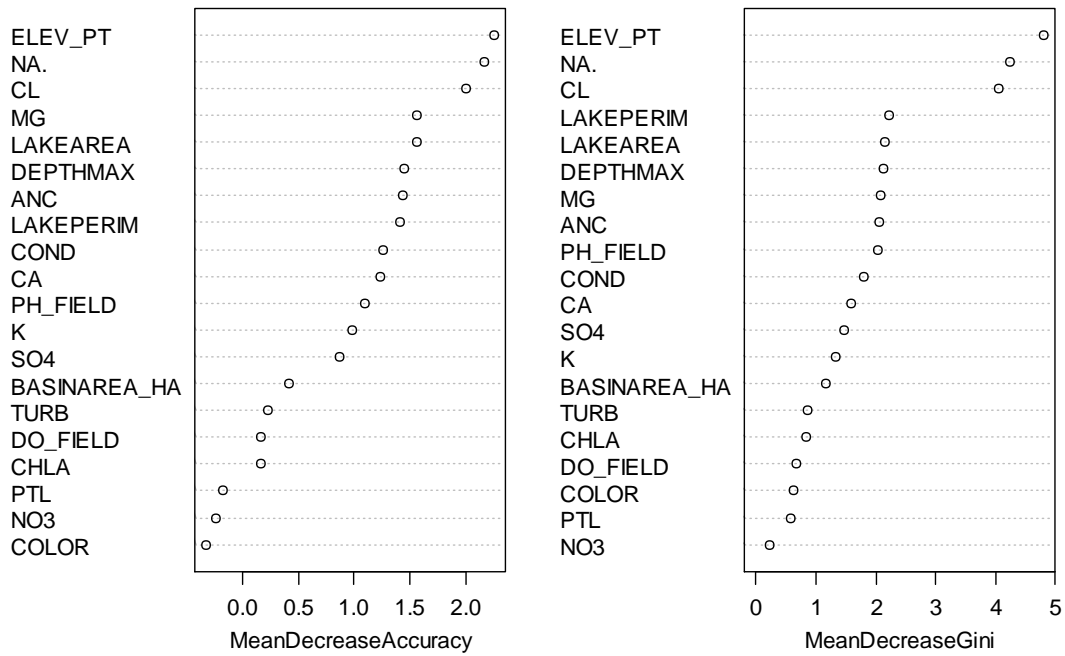
Our final classification tree predicting loon presence or absence in New England using the 20 WDSE candidate predictors consisted of 2 terminal nodes with a residual mean deviance of 0.06 (Fig. 8). Again, Cl<sup>-</sup> concentration, an index of pH (acid neutralization capacity instead of sulfate in this model), and lake surface area were important variables for predicting loon distribution. Chloride concentration split the data in half at a value of 158.3 ueq/L. At levels higher than this, the acid neutralization

capacity of the lake positively predicted presence (threshold = 754 ueq/L). At lower  $Cl^-$  concentrations lake surface area positively predicted loon presence (threshold = 33.9 ha).

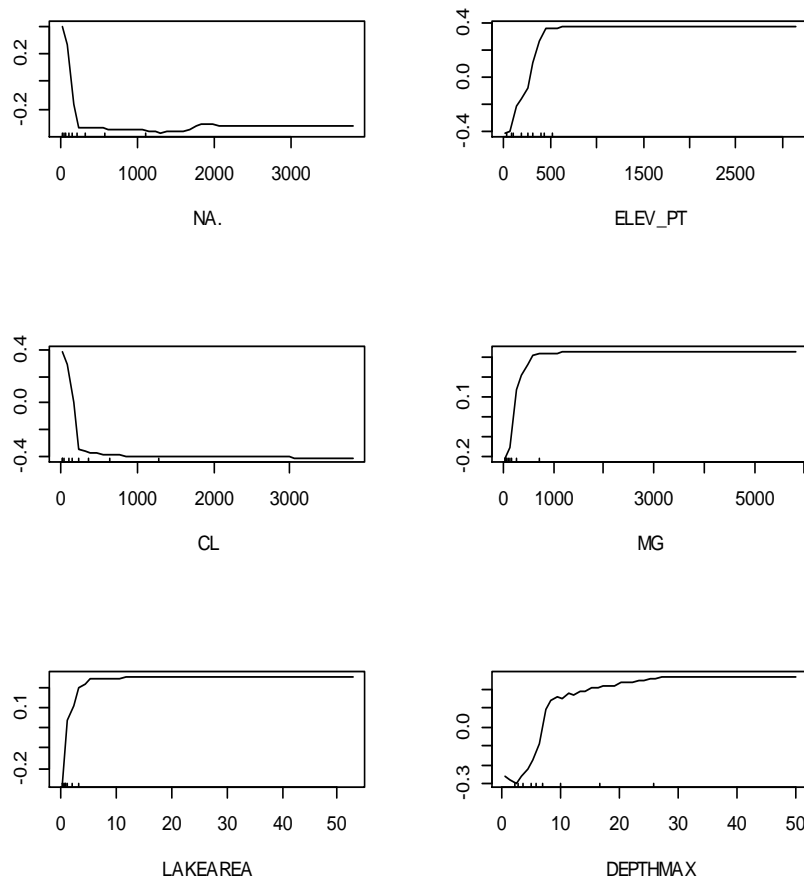


**Figure 10. Classification Tree For New England.** Full and “pruned” (pruning is not justified by cost-complexity analysis) classification tree: common loon presence/absence model for New England states using a reduced number of predictive variables (20), United States, 2005-2009. Predictors used in this model are the same as those used in the analysis of loon productivity in New England. Predicted values for splitting decision (i.e. thresholds) and number of cases are presented at each node. Predicted values for occupancy (0= absent, 1 = present) and number of cases are presented at each terminal node. Each node (i.e. split) is shown as an inequality. If the inequality is true, follow the left branch; if not proceed to the right branch.

The plotted mean decreases in accuracy and Gini indices for the variables in the model showed that elevation,  $Na^+$  levels, and  $Cl^-$  levels were the most important variables (the first splits of the trees, Fig. 11). We saw similar patterns for  $Na^+$  and  $Cl^-$  concentrations in this smaller scale, reduced dataset as the continental scale tree where each had low and abrupt thresholds for loon absence (negative relationship). Lake magnesium, elevation, maximum depth, and surface area all had sharply increasing relationships with the logit probability of presence (Fig. 12).



**Figure 11. Random Forest For New England Analysis.** Mean decrease in accuracy and mean decrease in Gini Index of all 20 variables for random forest model of presence/absence in New England, United States using 20 predictive variables, 2005-2009. Variables higher on the list are more important to explaining the response variable than those lower on the list. For a full description of the indices, see Fig. 8.

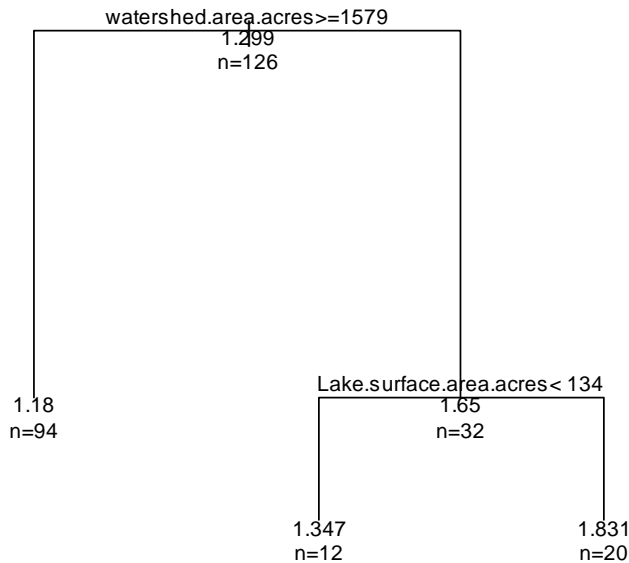


**Figure 12. Dependence Plots For New England Analysis.** Partial dependence plots give a graphical representation of the marginal effect of a variable on the probability of presence or absence, 2005-2009. These are partial dependence plots for the top six most important variables for the New England analysis of common loon distribution along their southern range edge in the United States.

### 2.4.3. Regional Productivity Descriptors

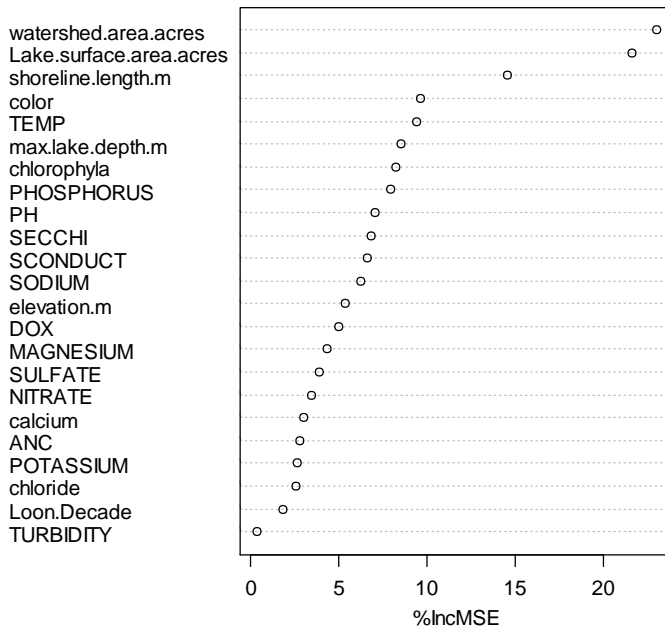
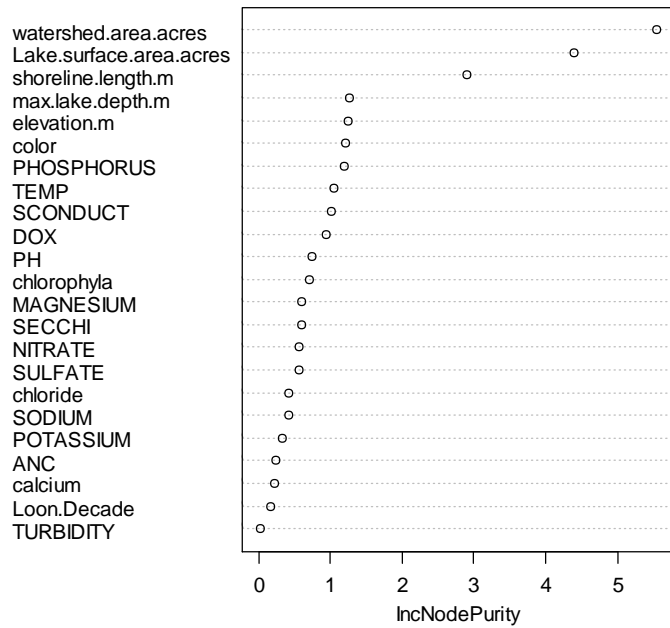
Our full regression tree for the analysis of productivity in the New England dataset used eight of the 20 candidate variables (eleven nodes) to construct the initial classification tree; however, the pruned tree only retained two of these variables: watershed size and lake surface area (Fig. 13). Lakes with smaller drainage basins (threshold = 639.0 hectares) had lower loon productivity than lakes in larger drainage

basins, and these lakes had the lowest predicted productivity of the three terminal nodes (1.2 chicks per pair per lake). Large lakes (threshold = 54.2 hectares) in larger drainage basins had the highest productivity (1.8 chicks per pair per lake). tree for productivity model



**Figure 13. Regression Tree For Productivity Model.** Pruned regression tree: common loon productivity model for loons in New England, United States, 1980-2010. Predicted values for splitting decision (i.e. thresholds) and number of cases are presented at each node. Predicted values for productivity (number of chicks per loon per decade) and number of cases are presented at each terminal node. Each node (i.e. split) is shown as an inequality. If the inequality is true, follow the left branch; if not proceed to the right branch.

For our random forest validation, our OOB error rate for our model was 13.2%, which explained 42.4% of the variance. Drainage basin area, lake surface area, and shoreline length were the highest ranked variables to split the data (Fig. 14). We were unable to create partial dependence plots for the model as our original data contained too many missing values (the tree itself is robust to these missing values (Breiman 2001) but the partial dependence plotting procedure is not).



**Figure 14. Random Forest For Productivity Analysis.** Percent increase in mean squared error and increase in node purity all 20 variables for random forest model of productivity (continuous response variable) in New England, United States using 20 predictive variables, 1980-2010. Variables higher on the list are more important to explaining the response variable than those lower on the list. These measures are analogous to the mean decrease in accuracy and Gini Indices used for a binomial response variable.

## 2.5. DISCUSSION

### 2.5.1. Continental-scale Range Descriptors

Lake  $\text{Na}^+$  concentration,  $\text{Cl}^-$ , and  $\text{SO}_4$  were the most important predictors of loon presence across the loon southern range edge in North America. The initial node with  $\text{Na}^+$  identified 67% percent of the lakes without loons (tree: Fig. 9), and eliminated lakes both within and outside the modern loon range. Our random forest analysis were convergent with our pruned classification tree findings regarding the importance of  $\text{Na}^+$  (ranked most important variable in random forest; Fig. 8). Kuhn et al (2011) modeled presence/absence in the New Hampshire and found that loons appeared to avoid human-altered landscapes with high road densities and high levels of agricultural activity. A similar process may be at work on a continental scale, as our results could be explained by either a direct choice in  $\text{Na}^+$  levels, or the absence of other large landscape-level disturbances, such as agriculture, development, or livestock grazing, which may alter lake chemistry and increase  $\text{Na}^+$  levels (Dale 1997).

Lake  $\text{Na}^+$  concentration was the best indicator of continental loon distribution in our random forest model (Fig. 10) and in our classification tree model. We do not suspect this finding is due to an intolerance to  $\text{Na}^+$ , as loons winter in marine environments and have adaptations (e.g. large nasal glands, specialization of the kidneys) to eliminate excess salt; however, further investigation into this realm is warranted. We hypothesize instead that loons may be sensitive to the trophic effects of increased salinity in freshwater ecosystems. Aside from natural variation in bedrock and net evaporation, differences in lake  $\text{Na}^+$  levels are generally attributed to the runoff of road salt and chemical deicers, which can elevate both  $\text{Na}^+$  and  $\text{Cl}^-$  levels in lakes (Rosenberry et al.



1999, Ramakrishna and Viraraghavan 2005) and suggests that loons may be less likely to occur on lakes with high amounts of deicer application in the drainage basin. Across the nation about 11 million tons of chemical deicers and road salts are spread each year (Keating 2004), 85% of which are used in the mid-Atlantic, Great Lakes, and New England states (Kaushal et al. 2005). This practice may be limiting the current distribution of loons in these high-use regions. With climate change, interactions between weather and human responses may alter this limitation. The average area of snow cover in North America has decreased by 0.7 million square miles since the 1970's, with the lowest value in 2006 (Armstrong and Brodzik 2006, Robinson and Heim Jr. 2006) and these trends are predicted to continue (Barnett et al. 2005). If the southern distribution of loons is indeed limited by the ecosystem effects of road deicing, a warmer world with less snow and ice may actually allow loons to recolonize some or all of their former range. Alternatively, deicers may be a general index of human land use, as  $Cl^-$  concentration in lakes has also been linked to human disturbance in the drainage basin (Herlihy et al. 1998). Under this scenario, we would not predict loon range expansion in the near future, as human development is unlikely to reverse in the mid-Atlantic and Midwest states.

Recent changes in the southern limit of the loon range support our initial hypothesis. Historically, loons have been reported to breed in locations further south than their current distribution in areas of northeast California, northern Iowa, southern Minnesota, northern Illinois, southern Wisconsin, northern Indiana, southern Michigan, northern Ohio, and northeast Pennsylvania where there are no modern records of breeding (Evers et al. 2010). Loons began breeding in northern Massachusetts

approximately 40 years ago and in parts of Pennsylvania 30 years ago, both of which represent either range expansions or a recolonization of their former range in these areas (Evers et al. 2010) and may suggest a role for deicer application in current loon range limitation.

Our variable dependence plots from the random forest model suggested a more abrupt threshold for lake chemistry variables (such as  $\text{Na}^+$ ) than other landscape level factors (Fig. 9). This pattern, however, may be attributed to correlations with other ions that we did not test. For example the restriction of lake outflow creates a more saline environment and increased levels of a large suite of ions (Wetzel 2005). Among the twenty-four ions we tested (Table 8), however,  $\text{Na}^+$  repeatedly outperformed the others. It is important to note that lakes with the highest  $\text{Na}^+$  concentrations were largely found across the southern breeding range, suggesting that an untested correlate of latitude may also be responsible for this pattern.

Another significant, positive predictor of loon occupancy was lake surface area. Previous studies have analyzed lake surface area effects on loon occupancy and loon reproductive success. Alvo et al (1988) found that lake surface area provided significant discrimination between lakes where chicks were successfully raised versus where they failed. In this study, lake surface area was related weakly but significantly to depth, and neither depth nor surface area was related to water chemistry variables (as found in other studies; Blenckner 2005). If lake surface area is driving the patterns with occupancy directly, it is unlikely to change dramatically with climate change, although changes in precipitation may change lake areas locally.

Loons may be sensitive to landscape-level forest changes, as three forest cover variables were determined important in our top eight variables in our random forest analysis (including one variable that our scree plot suggested was of the most important variables). Climate change is expected to impact forest ecosystems in inconsistent ways on varying spatial scales, with changes in disturbance regimes (Dale 1997) and plant species ranges (Matthews 2004). A more immediate and likely change in many areas across the northern United States over the next few decades will be from increased population growth, local urbanization, and changes in ranching and farming practices (Dale 1997). These land-use changes threaten to alter existing forested landscapes, which may impact lake suitability for loon persistence. The percentage of mixed forest cover in the drainage basin, however, primarily delineated northern lakes from southern lakes, and therefore it is possible that the relationship we detected is driven by an untested factor that also correlates with latitude (e.g. air temperature, day length, ice coverage).

While we would have ideally validated the results from our nationwide model with a nationwide demographic model, this was not feasible due to incomplete data across the entire southern range, a common constraint of demographically driven range models. The strength of our approach, however, is that it allows for demographic analysis in a portion of the range where these data are available. Creating an occupancy model of the entire southern range allows for a comparison with the predictors from this model with the variables that predict productivity in a portion of their southern range. Further, creating an occupancy model for this same reduced area assures that any differences detected are not due to a difference in scale rather than a difference in mechanism.

### 2.5.2. Regional-scale Range Descriptors

To test whether the same factors influencing loon distribution on a continental scale were operating on a regional scale, we analyzed data only for the lakes in New York and New England states using fewer predictors. The variables retained ( $\text{Cl}^-$ , acid neutralizing capacity, and lake surface area) in the regional model were similar to those retained on the national scale.

$\text{Cl}^-$  is a major anion in saline lakes (Wetzel 2005), and as the compound  $\text{Na}^+\text{Cl}^-$  is a common road deicer, the identification of  $\text{Cl}^-$  in this model may be analogous to the importance of  $\text{Na}^+$  in our continental analysis. While coastal lakes can receive marine-derived  $\text{Cl}^-$  ions from atmospheric transport (Wetzel 2005),  $\text{Cl}^-$  increases are generally due to pollution from road salt and municipal wastewaters (Sonzogni et al. 1983, Kaushal et al. 2005).

A second variable, acid neutralizing capacity (ANC), was retained in our model (ANC was a candidate predictor in the NLA dataset: Table 7). Total alkalinity levels are a chief determinant of ANC (Wetzel 2005), and high alkalinity lakes are often more biologically productive and less susceptible to the effects of acid precipitation (Driscoll et al. 2003). Loons were largely present, therefore, on more productive lakes with higher buffering capacities. The strength of the association between loon presence and ANC value was not strong enough to be selected as a top predictor in the nationwide model, yet in New England where lakes are categorized as “acid-sensitive” by the EPA (Driscoll et al. 2003), the strength of this association was much more prominent. As our small-scale models did not include lakes to the south of the current loon range boundary, however,

the inclusion of ANC in this tree may indicate that there are landscape characteristics that predict unoccupied lakes within the range that are not predictive of the range edge itself.

While ANC appears to predict local lake occupancy and not larger scale range edges, its local impact may increase with a changing climate. Although declines in atmospheric sulfur dioxide emissions over the last several decades have helped to increase ANC levels in lakes (Driscoll et al. 2003), climate-related events are reversing this process (Laudon et al. 2004) via increased atmospheric acidic deposition (Magnuson et al. 1997, IPCC 2007). Depending on position in the drainage basin, lakes that receive less groundwater will be particularly vulnerable to acidification in drier years (Magnuson et al. 1997). Predicted increases in summer drought intensity and frequency are expected to increase acidic episodes in water bodies and cause declines in ANC (Laudon et al. 2004). Alterations in ANC, alkalinity, and lake pH could all have detrimental effects on loon productivity and persistence on specific lakes within the loon range (McNicol et al. 1995).

### **2.5.3. Regional-scale Productivity Descriptors**

Decadal productivity averages in New England were positively associated with both drainage basin area and lake surface area. While lake surface area is unlikely to change dramatically with climate change, lake surface area can indicate risks to nesting success in the form of flash floods (which could inundate eggs) or droughts (which will make it difficult for loons to push themselves across land to get to their nest) because of correlations between lake size and position in the watershed. These potential climate induced disturbances to nest success are, in fact, encountered to a lesser degree today during extreme rainfall events or on reservoirs that draw water off quickly (Desorbo et al.

2007). Loon populations have persisted in most areas that experience these disturbances, despite the increased challenge of successfully producing chicks (Evers et al. 2010).

Drainage basin size may be important due to its similar relationship to risk of lake level variation or to other correlates with the land- cover of the drainage basin (e.g. forest cover). Because drainage basin size and lake size were the most important factors in predicting reproductive success, we are encouraged by the fact that these are not factors that are likely to alter with climate change scenarios. If, however, these two variables are important because of links with water-level variability, changes in precipitation regimes may influence loon productivity by increasing or decreasing such risk.

While other studies have found patterns between loon productivity and the variables we rejected (e.g. water clarity, water surface temperature, and dissolved organic carbon), most of these studies were on a smaller scale. Undoubtedly, these correlations between loon productivity and lake characteristics do exist, and may be important on a smaller scale or within a single drainage basin. On a regional scale, however, the individual effects did not predict the difference between occupied and unoccupied lakes.

#### **2.5.4. Validating Envelope Models with Hierarchical Decision Trees**

Our goals were to identify variables that were important in determining distribution and productivity and distinguish which variables were important in one realm, the other, or both. Our smaller scale presence/absence model identified subsets of the continental drivers of loon range edge and thus relationships appear to vary across space, but continental scale decision trees capture smaller-scale relationships. Lake salinity (measured by  $\text{Na}^+$  or  $\text{Cl}^-$ ), acidity (measured by  $\text{SO}_4$  or ANC), and surface area, were all important in determining loon presence at both a continental and regional scale.

Our productivity model validated the demographic underpinning of two variables as loon range predictors: lake surface area and drainage basin size. Forest composition of the drainage basin was a consistent predictor of loon presence at both regional scale and, to a lesser degree, the continental scale. Forest composition is driven by variables that are scale dependent (e.g. substrate, climate, graving, site history, etc. vary on a local versus site scale (Corney et al. 2006). Although we did not directly test forest composition in our productivity model, the only drainage basin variable we did test, drainage basin size, was an important predictor of loon productivity. This underscores the demographic importance of the drainage basin to loons and suggests a possible demographic mechanism for its power as a range predictor.

Our method of pairing our occupancy model with a demographic model made us more confident in our occupancy model results. The productivity model rejected lake salinity and acidity as predictors. While these two predictors appeared important at both the regional and continental scales, we found no ties with offspring production. This does not mean, of course, that there is no demographic underpinning to these two variables. They may influence settling rate (immigration) or apparent site fidelity (emigration and survival). On the other hand, they may be spurious due to correlations with another demographically important variable. Our approach allowed us to reject their linkage with productivity, and further investigations could test for linkages with other demographic mechanisms. Without the hierarchical validation, however, we would not have been able to distinguish between the two predictors that were related to productivity and the two predictors that were not.

### **2.5.5. Implications for Climate Change on the Range of the Common Loon**

Our overall findings regarding the probability of loon persistence within the United States are promising. All of our demographically validated variables that explain loon distribution are unlikely to change with climate, although we need a better understanding of how drainage basin composition and lake size influences productivity to be confident. Of the range predictors that were not related to loon productivity, two were unlikely to change greatly due to climate (salinity and acidity/alkalinity). In both of these cases, however, we need to be conservative in our predictions until we understand why these characteristics predict the current loon range. If they are not validated through a demographic mechanism other than productivity, these relationships may be spurious and their predictive ability for future range shifts severely limited. Smaller scale studies have suggested demographic linkages between loons and acidity/alkalinity, but we recommend additional large-scale investigations to validate this lake characteristic at a continental scale. Overall, however, we believe our generalized approach of a continental envelope model followed by smaller scale machine learning techniques to validate the demographic underpinnings of important variables represents a distinct step forward in developing range models that will accurately predict range shifts with landscape and climate change. In this case study we were able 1) to reject or support the productivity underpinnings of range predictors from an envelope model and 2) reject the ability of a number of variables, which were previously identified as important for loon demography, to predict the current range of the common loon. This approach should work equally well with many species to identify variables that are both accurate predictors of current ranges and tied to demographic mechanisms likely to lead to range changes in the future.



It is important to recognize that our analysis only addresses loon persistence in the United States during a portion of their annual cycle. Loons that breed in the continental United States spend the entirety of their winter on the Atlantic or Pacific Oceans, or, less commonly, on unfrozen freshwater systems near the ocean (Evers et al. 2010). Future changes in ocean conditions that lower winter survival or energy stores required for migration and subsequent breeding may have larger impacts on the common loon breeding range than changes directly to breeding lakes themselves.

|

**CHAPTER 3**  
**BLOOD METABOLITES AS INDICATORS OF BREEDING HABITAT**  
**QUALITY: A SENSITIVE METHOD TO PREDICT RANGE**  
**ALTERATION UNDER CLIMATE CHANGE?**

**3.1 ABSTRACT**

Climate change has the potential to shift and/or restrict species' ranges. While previous studies have generally failed to predict range alteration successfully, individual energetic condition may offer more potential because it can identify covariance between energetic condition and breeding habitat quality. We used blood metabolites and behavioral observations to evaluate the energetic costs of common loons (*Gavia immer*) breeding on lakes across a gradient of environmental, spatial, and behavioral conditions. Using these physiological and behavioral endpoints we created a framework for evaluating the effect of environmental characteristics on the value of breeding locations along the species' southern range edge (ME, NH, MA, MT, WA). Using samples collected over two years (n=97), blood triglyceride concentrations suggest that the number of chicks, breeding latitude, and daily temperature are important predictors of loon energy expenditure. Specifically we found that: 1) loons with two chicks expend more energy than those with one, 2) loons near the southern range edge expend more energy to produce a given brood size than those nearer the range center and, 3) birds breeding in warmer temperatures expend more energy than those in cooler temperatures (controlling for year, territory type, and calendar date, free glycerol levels, size-corrected body mass, and longitude). We suggest that as environmental conditions change in the

coming years, blood metabolites offer a promising predictor of population collapse along range boundaries.

### 3.2 INTRODUCTION

Climate change is predicted to cause a range of effects on animal populations (IPCC 2007). In birds, the potential for range shifts, expansions, and contractions has already been realized by numerous species (Watkinson et al. 2004, Waite and Strickland 2006, Virkkala et al. 2008, Barbet-Massin et al. 2009, Martinez-Morales et al. 2010). Some of the hypothesized mechanisms behind these shifts include changes in food availability, phenological alignment, and thermoregulatory challenges (Brown et al. 1999, Walther et al. 2002).

One of the most common ways to predict how climate will alter bird species' distributions is through the use of bioclimatic envelope models. These models link the current geographical distribution of a species to climatic variables, and the predicted locations of these variables are then used to forecast the species' occurrence (Heikkinen et al. 2006). Most researchers agree that this method is only a first step in determining the predicted changes in distribution, and it should only be used as a guideline for further investigation (Pearson and Dawson 2003, Hampe 2004, Stanley and Royle 2005, Hijmans and Graham 2006, Heikkinen et al. 2006, Vallecillo et al. 2009) as distributions may not be limited simply by climate (Beale et al. 2008). Models that link species' ranges to explicit ecological and demographic processes have proven more useful in predicting the effects of habitat degradation (from climate or other rapid landscape changes) on animal distributions (Holt and Keitt 2005, Byrd 2012, Chpt. 2). Metrics that influence the

demographic processes underlying range edges are the most valuable for determining how alterations in these parameters may change future distributions.

In order to link an organism's distribution with an individually based mechanism of distribution change, it is important to examine the relationship between physiology and environment. Linking physiology to microclimatic data in a scalable way is the key to understanding a species' distribution (Hodkinson 1999). Species-specific physiological thresholds of temperature, for example, are known to limit the distribution of a wide variety of organisms (Nickerson et al. 1988, Walther et al. 2002, Pörtner 2002), and it is reasonable therefore to assume that we can detect initial differences in metabolic expenditure under thermal conditions that are less extreme than those needed to cause local extirpation. This initial variance could then potentially act as a harbinger of larger scale population changes.

Body mass is a widely used estimate of energy stores as it is noninvasive and easy to measure, and changes in body mass can give an indication of changes in energy stores (Jenni-Eiermann and Jenni 1994). This method of determining stores of fat reserves, however, has shortcomings. These include the need to recapture animals (e.g. energy stores might influence recapture ability) and the potentially adverse effects of capture on fat acquisition (Jenni-Eiermann and Jenni 1994).

Blood metabolites are one potentially useful link between environmental conditions and individual energetic expenditure that can shed light on an individual's ability to deal with changing environmental conditions (Brown et al. 1999). Plasma metabolites are the products of intermediary metabolism and are measured in the bloodstream between their origin within an organ and their delivery to another location in

the body (Jenni-Eiermann and Jenni 1998). Therefore, concentrations of plasma metabolites relate to both the current energetic demand of an individual and the individual's ability to meet that demand. Very high triglyceride levels, for instance, can indicate that an individual is increasing caloric intake or fat reserves (which may suggest that it is more buffered from environmental changes; Quillfeldt et al. 2004). Conversely, triglycerides are hydrolyzed during fasting (to increase fatty acid and glycerol availability), and thus lower triglyceride levels and elevated glycerol typify fasting (or possibly starvation) in birds (Carey 1996). Overall, plasma metabolites can be viewed as correlates of the net balance of stored energy from the preceding hours (Jenni-Eiermann and Jenni 1998).

We examined free glycerol and triglyceride concentrations in the blood of brooding common loons (*Gavia immer*) to assess the energetic demand of birds in different environments along the species' southern range extent. We predicted that we would detect low glycerol values with little variation in our population of successfully breeding loons (captured at night during fasting). Free glycerol has shown no nightly or diurnal trend in birds fasting through the night (Jenni-Eiermann and Jenni 1997) and concentrations were generally low in a study of garden warblers (*Sylvia borin*) when an individual's body mass was increasing or when fat reserves were stable (Jenni-Eiermann and Jenni 1994). In this same study, triglyceride levels followed the opposite pattern where the highest values occurred during fattening and the lowest values occurred during fat loss. Because our loons were successfully breeding, we assumed that they were in relatively high condition (low glycerol and higher triglycerides). Because we caught them all during their nightly fast, we expected varying concentrations of triglycerides as a

function of net energy assimilation and use from the previous day. Therefore, we predicted that we would see differences in triglyceride levels which would indicate energetic state. This same link between fat reserves and triglyceride levels has been found in two studies of fasting gulls (Totzke et al. 1999, Alonso-Alvarez and Ferrer 2001). Further, a study of reed warblers (Jenni and Schilch 2001) concluded that triglyceride levels were better predictors of changes in lipid stores than overall change in body mass. Finally, while a study of thirteen species of seabirds near Shumigan Island, Alaska found no differences in triglyceride levels in various stages of breeding condition, all of our samples were collected from loons that were brooding chicks to control for variation due to breeding stage.

In the past several decades, the population growth rates of common loons (*Gavia immer*) have declined in several regions of the northern United States (Sidor et al. 2003, Karasov et al. 2007, Evers et al. 2008, Grear et al. 2009) and the collapse of populations in this southern portion of the range has been predicted by a bioclimatic envelope model (Matthews 2004). The best predictors for both loon distribution and seasonal productivity in North America, however, are fairly robust to near-term changes in climate and are more sensitive to human disturbance (e.g. forest cover in the drainage basin, Na<sup>+</sup> levels in a lake, lake surface area: Byrd 2012, Chpt. 2). We expect, however, that if range contraction along the southern extent of the loon distribution occurs due to changes in the breeding environment, the cost of reproduction will increase prior to the appearance of measurable changes in demographic variables such as offspring production or bird abundance. Demographic models agree that changes in factors affecting adult survival are more likely to cause population change than variation in fecundity directly

(Gear et al. 2009). Evaluating the energetic demand of breeding adults will help to understand the conditions within the current breeding range that are most likely to affect population viability and cause range contractions.

To construct a more physiologically mechanistic model of common loon persistence, we examined the way in which environmental and social parameters at different scales varied with the blood triglyceride concentration of individuals on the breeding grounds, controlling for glycerol concentrations. These relationships may then identify environmental variables that impact adult survival and control both loon population viability and drive range changes. Here, we examine common loon triglyceride levels to link environmental variance with energetic condition during what we believe is one of the most energetically demanding portions of the loon life cycle, chick rearing.

### **3.3 MATERIALS AND METHODS**

#### **3.3.1. Study Population, Field Methods, and Lab Assays**

Loon captures took place between May and August of 2010 and 2011. Blood samples were collected in Maine (n= 77), New Hampshire (n= 22), New York (n= 4), Washington (n = 4), and Montana (n= 4). Breeding adults with chicks were captured at least 30 minutes after evening civil twilight using both spotlighting and playback recordings (Evers 1992, 2001b). To identify individuals in the future, loons were fitted with unique color bands in addition to a USGS issued metal band. All individuals were of known sex, were caring for chicks, and were captured at night (i.e. were fasting: Evers et al. 2010). Standard morphometric measurements were taken (e.g. tarsus width, weight, bill length) to create an index of body size (Senar and Pascual 1997). Within fifteen

minutes of capture, we collected a blood sample in a heparinized capillary tube following the venipuncture of the metatarsal vein. The samples were kept on ice until centrifuged (within six hours) at 6000 rpm for 10 minutes. Plasma was frozen until laboratory assays were performed.

We conducted triglyceride/free glycerol assays to determine the levels of free glycerol, total glycerol, and triglycerides from blood samples. Assays were conducted in accordance with the Triglyceride/Free Glycerol Assay Protocol from the Holberton Laboratory of Avian Biology (Holberton 2008). Using a colorimetric enzymatic endpoint assay we measured plasma glycerol levels (GPO-Trinder Assay, kit 337; B Sigma-Aldrich, St. Louis, Missouri). Plasma samples were run in duplicate using 96-well plates and read on a SpectraCount reader (Packard, Palo Alto, California). We used a commercial standard of known triglyceride levels and created a standard curve to standardize our results.

### **3.3.2. Behavioral Observations**

We recruited biologists from four Northeastern states to gather behavioral observations of 113 loon territories. In particular we were interested in the frequency of escalation of territorial interactions. We expected that one of the most energetically expensive activities in which territorial birds could engage would be territorial disputes. During these interactions, territorial birds (both males and females) may chase intruders around the lake at high speed while “rowing” with their wings on the surface of the water. They may also physically grapple, beating their wings against one another and attempting to spear their opponents with their bills (Piper et al. 2000, 2008b, Evers et al. 2010). Not all interactions escalate to this level, however, and interactions may end after



as little as a vocal call and some slight changes in posture. Territorial defense in birds may account for 0.9 to 33.1% of daily energy expenditure during the height of the breeding season (Walsberg 1983). While 41.5% of territory acquisitions in loons occur through passive takeover (desertion or death of previous territory holder), the same percentage of acquisitions occur through the active displacement of a member of the resident pair or through earlier arrival time at the territory (Piper et al. 2000). Thus, defense of a territory has the potential to require a large portion of a loon's seasonal energetic budget.

We hypothesized that the likelihood of an intense escalation was at least partially a function of the energetic condition of the territory holder. Biologists across New Hampshire, New York, Vermont, Massachusetts, and Maine recorded the frequency of territorial intrusions and the level of escalation of an interaction by the territory holder (“passive”: intruder is present but territory holder is not currently engaged in an aggressive interaction or “active”: territory holder is having an aggressive interaction with intruder including peering, circle dancing, pursuing, directly physically contacting intruder, directly vocalizing at intruder, or other) from May-August of 2010 and 2011. Loons were observed from the lakeshore or from a kayak and the first behavior observed by the researcher were recorded. Behaviors were recorded separately for both members of the pair and marked individuals were differentiated when possible.

### **3.3.3. Statistics**

In order to determine the average triglyceride and free glycerol levels in our samples, we used Microsoft Office Excel (2007) to find the mean and standard deviation of our measures.

We identified 17 candidate variables *a priori* that made biological sense based on field observations, exploratory data analysis, and published literature. Candidate predictors of loon condition explained variation in the immediate landscape (2), in the larger region (2), in the local social environment (3), in the timing of the sample (6), and among individuals (4).

We identified four spatial variables. Our two landscape-scale effects included drainage basin area and lake surface area, both of which are landscape-level predictors of loon productivity (Byrd 2012, Chpt. 2). Lake surface area may correlate with several social parameters, as well. Nocera and Burgess (2002) found that lake surface area was positively correlated with dive-pause times and variation in dive-pause times, which they speculated was because loons on larger lakes may be more apt to encounter intruders (through interactions with adjacent territory holders as well as loons from other lakes) and therefore must remain on the surface for longer periods to successfully defend their territory. Additionally, larger lakes potentially support a greater number and diversity of nesting locations and habitat variation, which may be preferred by loons. The information for the lake attribute fields was gathered from the Environmental Protection Agency Wildlife Database Search Engine (<http://oaspub.epa.gov/aed/wildlife.search>) and the USGS National Water Information System (<http://nwis.waterdata.usgs.gov>). We also accounted for spatial variation at the regional scale by including latitude and longitude (decimal degrees).

We included three characteristics of the social environment previously found to influence loon behavior. First, we characterized each loon territory as one of three types. Loons breed on multiple lake territories (where their territory is comprised of many

lakes), whole lake territories (where there is one pair of loons on one lake), and partial lake territories (where more than one pair is on a given lake; Evers et al. 2010). All of the territories in this study were either whole lake or partial lake types. We predicted that loons on single-lake territories would encounter lower energetic demands as they do not defend shared territory boundaries with other pairs, nor do they need to fly to other lakes to meet their nutritional requirements, as they do on multi-lake territories (Piper et al. 1997b). Second, we included both the number of pairs on the lake and the interaction between number of pairs and lake surface area to account for potential increases in territorial interactions with bird density on various lake sizes.

We accounted for temporal variation in the triglyceride concentration by including six potential variables. We included the sampling year to account for year-to-year variation and julian date to control for seasonal variation. To account for the potential impacts of the local weather prior to sampling on triglyceride levels, we included the minimum and maximum daily temperature (to the nearest tenth of a degree C) on the day prior to the night of capture and the two, two-way interactions between temperature (minimum and maximum) and year to account for variation in this relationship among years. Weather data were collected from the National Oceanic and Atmospheric Administration's National Climatic Data Center (<http://www.ncdc.noaa.gov/>) from the closest land-based weather station with historical data for the day in question.

Lastly we included four variables that controlled for intrinsic individual differences. We included sex to detect possible differences between male and female triglyceride levels (e.g. energetic demands of incubation; (Williams 1996, Thomson et al.

1998, Evers et al. 2010; or territory defense; Piper et al. 2008) and the number of chicks produced (1 or 2) to account for potential differences in the energetic demands of different brood sizes (Deerenberg et al. 1995, Lozano and Lemon 1998). As body mass is an important variable for interpreting metabolite results (Jenni-Eiermann and Jenni 1994), we included size-corrected body mass (weight/tarsus) in our model. Lastly, we included free glycerol concentration as a candidate predictor, because the relationship that circulating triglycerides have with free glycerol can help explain the stage of fat acquisition or depletion that an organism is experiencing (Jenni-Eiermann and Jenni 1994, Guglielmo et al. 2005).

Candidate models were all repeated-measures, mixed-effects models (LMM) using maximum likelihood (“ML”; package ‘nlme’ in R 2.14.1; Jose Pinheiro et al. 2011) with the lake of capture was a random effect. Model selection was conducted using stepwise AIC model selection (“stepAIC”, package ‘MASS’ in R 2.14.1; (Venables and Ripley 2009), using backward selection. Optimal variance and correlation structures for the models were selected using Akaike’s Information Criterion (AIC) values (Pinheiro and Bates 2000, Zuur et al. 2009), and models with  $\Delta AIC < 2.0$  were considered equivalent.

For our analysis of behavioral data, we used Microsoft Office Excel (2007) to determine the mean and standard error of our observations.

## **3.4 RESULTS**

### **3.4.1. Establishing Baseline Metabolic Measures**

Loons of differing mass were largely homogenous in energetic condition which allowed us to define the values for energetic regulation of known breeding individuals.

Using plasma samples (n=96), we established baseline levels of free glycerol ( $\bar{x} \pm SD = 0.157 \pm 0.080$  mmol/L) and triglyceride levels ( $0.875 \pm 0.376$ ) for brooding loons (Table 6).

**Table 6. Descriptive Statistics for Triglyceride and Free Glycerol Levels.** Descriptive statistics for the average triglyceride and glycerol levels of common loons (*Gavia immer*) with chicks in areas of ME, NH, MA, MT, WA during the summer of 2010 and 2011.

	n	mean	SD
Free Glycerol (mmol/L)	105	0.157	0.080
Triglycerides (mmol/L)	105	0.875	0.376

Our values were within the range of values found in (or extrapolated by) previous studies (see Chapter 3 of thesis). Our mean free glycerol levels are qualified as “low” based on previous measures of glycerol, indicating birds in a fasting stage (Jenni-Eiermann and Jenni 1998). Our mean triglyceride levels are also categorized as “low” (as we had predicted based on our nocturnal capture and breeding stage), but exhibited more variation than our glycerol values (51% vs. 43% of the mean).

### 3.4.2. Triglyceride Levels In Breeding Loons

Our model selection took eleven steps to identify three, equivalent models ( $\Delta AIC < 2$ ; Table 7) of triglyceride variation that included nine variables (in addition to the random effect of the lake of capture) (cumulative Akaike  $w_i > 0.8$ ). The parameter estimates for number of chicks, latitude, and the interaction between year and maximum temperature during the day preceding capture were all significantly different from zero. The number of chicks was negatively related to blood triglycerides in the adults and the latitude of capture was positively related to triglyceride concentrations. There was a

significant negative relationship between the highest maximum temperatures and triglycerides in 2011 but not in 2010. Akaike weights for the top three models (out of eleven potential models) were 32.4%, 26.2%, and 24.1% respectively (Table 7). Number of chicks, year, territory type, latitude, free glycerol levels, maximum temperature, and the interaction of year and maximum temperature were found in all eleven models. We employed model averaging of the eleven models to create parameter estimates as a way to include model selection uncertainty into these values (Table 5). Model selection indicated that the inclusion of julian date, year, free glycerol levels, and longitude improved model support, but the 95% confidence intervals of these parameter estimates included zero, making it difficult to gauge their strength (Table 8).

Size-corrected body mass had no influence on triglyceride levels (was not a covariate in our top three models). A post-hoc analysis showed no relationship between triglyceride levels and the residuals of size-corrected body mass ( $r^2 = 0.003$ ).

**Table 7. Triglyceride Probability Models.** Random effects model selection results for factors affecting the level of triglycerides in plasma samples collected from common loons in ME, NH, MA, MT, and WA, United States (2010 & 2011). The first three models performed equivalently ( $\Delta AIC < 2$ ), and all models contain the variables in the top-listed model in addition to those in each row.  $\ln(L)$  is the value of the maximized log-likelihood function,  $AIC$  is Akaike's information criterion,  $\Delta AIC$  is the scaled  $AIC$  relative to the top model,  $k$  is the number of model parameters, and  $w_i$  is the Akaike weight, which provides a relative measure of support for a given model. Models were fit with maximum likelihood (ML). Variable abbreviations are as follows: chicks (number of chicks a pair was caring for), year (capture year), fg (free glycerol levels in mmol/L), terrType (either partial lake or whole lake territory), Lat (latitude), Long (longitude), TMAX (maximum temperature during the day preceding the night of capture), TMIN (minimum temperature during the day preceding the night of capture), year:TMAX (the interaction of year and maximum temperature during the day preceding the night of capture), year:TMIN (the interaction of the year and minimum temperature during the day preceding the night of capture), Julian (Julian calendar date of capture day), sex (sex of individual), numPairs (the number of pairs holding a territory on the lake of the captured individual), lakesurf (lake surface area in hectares), numPairs:lakesurf (the interaction of lake surface area with the number of pairs holding a territory on the lake), watershed (the area of the watershed in hectares), SZ\_COR\_BM (size-corrected body mass; mass divided by tarsus width).

<i>model</i>	<i>ln(L)</i>	<i>AIC</i>	$\Delta AIC$	<i>k</i>	$w_i$
m1 = chicks + year + fg+ terrType + Lat + TMAX + year:TMAX	-50.790	121.58	0	7	0.324
m1 + Long	-50.004	122.01	0.43	8	0.262
m1 + Long + julian	-49.087	122.17	0.59	9	0.241
m1 + TMIN + Julian + Long	-49.081	124.16	2.58	10	0.089
m1 + TMIN + julian + Long + year:TMIN	-48.683	125.37	3.79	11	0.049
m1 + TMIN + julian + Long + sex + year:TMIN	-48.566	127.13	5.55	12	0.020
m1 + TMIN + numPairs + sex+ julian + Long + year:TMIN	-48.492	128.98	7.4	13	0.008
m1 + TMIN + numPairs + lakesurf+ sex + julian + Long + year:TMIN	-48.446	130.89	9.31	14	0.003
m1 + TMIN + numPairs + lakesurf + sex + julian + Long + year:TMIN + numPairs:lakesurf	-48.400	132.80	10.78	15	0.001
m1 + TMIN + numPairs + lakesurf + sex + julian + Long + year:TMIN + numPairs:lakesurf + watershed	-48.395	134.79	11.22	16	<0.001
m1 + TMIN + numPairs + watershed + lakesurf + sex + julian + Long + year:TMIN + numPairs:lakesurf + SZ_COR_BM	-48.390	136.78	15.2	17	<0.001

**Table 8. Triglyceride Model-Averaged Parameter Estimates.** Parameter estimates from original 11 models and model-averaged parameter estimates with unconditional 95% confidence intervals for variables in the top three models for triglyceride levels in common loons (*Gavia immer*) in ME, NH, MA, MT, and WA, 2010 and 2011. Parameters considered include the number of chicks (0 or 1), year (2010 or 2011), territory type (single lake or shared lake), capture date (Julian), latitude and longitude of capture lake, maximum temperature on day of capture, and the interaction between year and maximum temperature. Values in the parentheses following each variable name indicate the reference level for binomial variables. Model-averaged parameters whose estimates are significantly different from zero are in bold text.

<i>Variable</i>	<i>fixed effects</i>	
	<i>coefficient</i>	<i>95% CI</i>
<b>Chicks</b>	<b>-0.209</b>	<b>-0.3935, -0.0264</b>
Year (2011)	1.202	-0.2816, 2.6844
Territory Type (partial-lake territory)	-0.221	-0.4848, 0.0433
Julian	-0.005	-0.0128, 0.0024
free glycerol	0.929	-0.3824, 2.2413
<b>Degrees North Latitude</b>	<b>0.125</b>	<b>0.0467, 0.3826</b>
Degree East Longitude	0.012	-0.0052, 0.0293
Maximum Temperature on Previous Day	0.001	-0.0026, 0.0040
<b>Year (2011) x Maximum Temp</b>	<b>-0.006</b>	<b>-0.0122, -0.0001</b>

### 3.4.3. Behavior

Among 1228 observations of 113 loon territories, we recorded 56 incidences of territorial intrusion on 32 territories. Only a single territorial pair ever exhibited both escalated and un-escalated (i.e. active and passive) territorial behaviors. For the 22 loon pairs for which both behavioral data and metabolite samples were collected, eight showed territorial behaviors, and loons that escalated interactions had lower plasma triglyceride concentrations than those that did not (Table 9), although the sample size is quite small.



**Table 9.** Descriptive statistics for the average triglyceride levels of common loons (*Gavia immer*) with intruding loons on their territory that either did not respond aggressively (passive) or responded with some degree of aggression (escalating) in ME, NH, MA during the summer of 2010 and 2011.

	$\bar{x}$	n	SE
passive	0.957	3	0.1365
escalating	0.784	5	0.0225

### 3.5 DISCUSSION

Our triglyceride levels suggest the loons we captured were in a fasting stage (lower overall triglyceride values, i.e. <2.0 mmol/L), which is corroborated by the timing of our sampling (nocturnal sampling in a diurnal foraging species). Within our range of values, loons with lower triglycerides have higher energetic demand as they are utilizing and mobilizing lipids more rapidly than the birds with higher plasma triglyceride levels (Jenni-Eiermann and Jenni 1998, Nagy et al. 1999, Price et al. 2008). Loons that escalated interactions had lower blood triglyceride concentrations pointing to an increased cost in escalating interactions with intruding males, as suggested by previous studies (Piper et al. 2000)

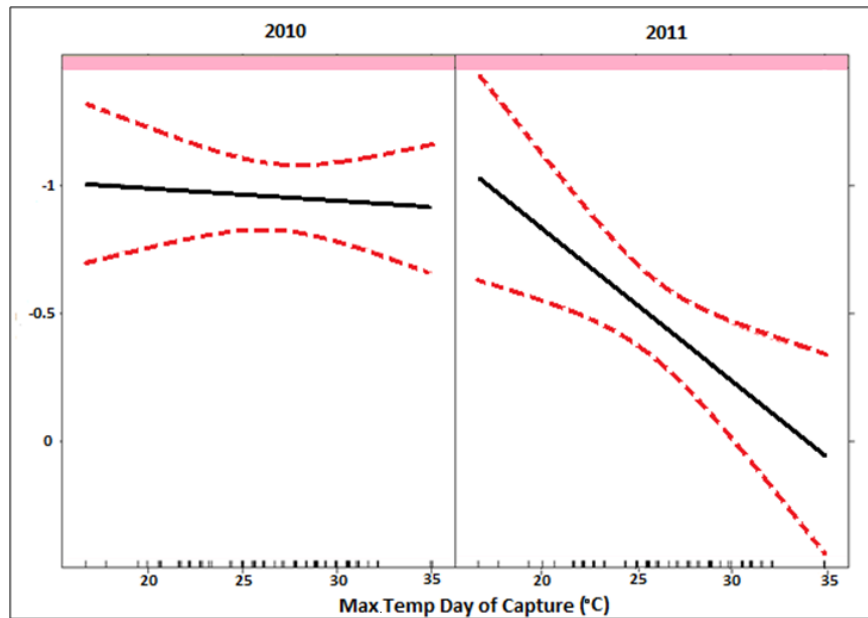
Our models suggested that energetic demand in breeding loons is influenced by factors on various scales. Our top-ranked models suggest that energetic condition as assessed by triglycerides is a function of a loon's individual breeding effort (the number of chicks produced), region (latitude, longitude), and weather conditions (maximum temperature and the interaction of year and temperature), controlling for the social environment (territory type), other metabolites (glycerol), and the time of sampling (julian capture date, year).

The number of chicks a loon cared for was negatively related to triglyceride values (when controlling for other variables in the model), which suggests that within our range of values, loons with one chick are less energetically taxed than those with two. Similar to our results, Deerenberg et al. (1995) found an increase in daily energy expenditure in European kestrels (*Falco tinnunculus*) with increased clutch size. More indirectly, decreases in mass are frequently reported during breeding in birds (for a review see Moreno 1989), suggesting increases in energetic demand are related to offspring production. This increase in energetic demand is likely a function of the required rate of provisioning, which is a function of brood size (Jodice et al. 2006, Gingras and Paszkowski 2006, Enstipp et al. 2007). Loon chicks are completely dependent on their parents for food during the first several days of life. By three weeks of age, they can chase fish for upwards of 30 meters, however their capture rate is still poor (3%), and parents supply chicks with most of their food until nearly eleven weeks of age (Gingras and Paszkowski 2006, Evers et al. 2010). Yellow warblers (*Dendroica petechia*) increase both their provisioning rate and energetic demand when clutch size is experimentally increased (Lozano and Lemon 1998), and a similar mechanism is likely at play in our system. Our results, therefore, suggest that a future drop in the number of loons brooding two versus one chick may signal an underlying physiological inability to care for a larger brood, which could signify larger shifts toward population inviability. What is unknown in our study species is how previous breeding experience impacts current breeding condition at a given brood size as has been shown in common terns (*Sterna hirundo*; Bauch et al. 2010).

Latitude was positively associated with triglyceride levels in our sample of loons, indicating that at more northern sites, loons face decreased energetic demand. Our latitude values ranged from 43.2 ° N to 48.8 ° N. Basal metabolic rate has been shown to correlate positively within vertebrate phylogenies with latitude (Weathers 1979, 1997, Weathers and Greene 1998). Our results are contrary to this larger pattern, but it is difficult to determine whether this is due to the relatively small latitudinal range over which we conducted the study or whether this is indeed a physiological symptom of a range edge. Collecting metabolites over a wider range of latitudes and along northern as well as southern range edges would help illuminate the generality of this trend.

Our results indicated that triglyceride levels were negatively related to maximum daily temperature on the day of capture on a given year (Fig. 15), suggesting that higher maximum temperature produced lower energetic demand in 2011 (while controlling for the other variables in the model, including latitude). Energy expenditure has been reported to decrease with ambient temperature in other bird species as well (Claudia Rauter and Reyer 2000). The strong relationship between metabolic demand and temperature was present only in 2011. We assume that the metabolic demand of loons is even more tightly tied to water temperature, since heat loss by endotherms in water is higher than in air at the same temperature due to the thermal conductivity of water (Jenssen et al. 1988). While water birds have mechanisms for increased thermoregulation owing to their aquatic lifestyle (e.g. plumage insulation, peripheral vasoconstriction), minimal thermal “wet” conductance in some waterbirds can be as much as 57% greater than conductance due to air (Jenssen et al. 1988). Unfortunately, we did not record surface water temperatures during capture. As mean global temperature increases (IPCC,

2007), however, loons may be more energetically taxed due to higher maximum temperatures during the chick rearing stage. Additionally, incubation is a thermoregulatory challenge for loons and other birds under warm temperatures (Eppley 1996). The loons within our study area regularly pant during incubation (which suggests they are above their thermal neutral zone), suggesting that higher temperatures may impact the overall cost of breeding more dramatically outside of the chick rearing stage. Higher temperatures over the long term will also likely influence prey species abundances and biomass (Ficke et al. 2007). Additionally, higher surface water temperatures will increase the strength and duration of lake stratification (Peeters et al. 2007), altering lake communities and food-web dynamics (Ficke et al. 2007). While loons are adapted to surviving on various different prey items (Evers et al. 2010), large-scale shifts in prey composition could potentially push loons out of once suitable breeding lakes regardless of any decrease in energetic expenditure on thermal regulation.



**Figure 15. Temperature/Year Interaction Plot.** An all-effects plot examining the relationship of year and temperature on triglyceride levels in common loons (*Gavia immer*), May- August, 2010-2011. Maximum temperature values on capture days ranged from 16.6-32.2 degrees C in 2010 and 17.9-35.0 degrees C in 2011. The relationship with the highest maximum temperatures is shown in the upper plot and lowest maximum temperature in the lower plot.

### 3.6 SUMMARY

Breeding birds must optimize the allocation of energy into self-maintenance and parental care (Martins and J 1993, Pettifor 1993) in the face of varying climatic conditions and food resources (Claudia Rauter and Reyer 2000). Blood triglyceride concentrations suggest that the number of chicks, breeding latitude, and daily temperature are important predictors of loon energy expenditure (controlling for year, territory type, and calendar date, free glycerol levels, size-corrected body mass, and longitude). Specifically we found that: 1) loons with two chicks expend more energy than those with one, 2) loons near the southern range edge expend more energy to produce a given brood size than those nearer the range center and, 3) birds breeding in warmer temperatures expend more energy than those in cooler temperatures (controlling for year, territory

type, and calendar date, free glycerol levels, size-corrected body mass, and longitude). Without taking further measures of physiology, biologists can monitor maximum temperature across years, and chick number (and latitude, if examining larger areas) and identify areas of vulnerability before reproduction halts entirely. Of critical importance as climate changes is monitoring changes in maximum temperature. While our findings suggest that warmer temperatures may reduce the cost of thermoregulation for breeding loons, our concern is in regards to the ways that temperature is predicted to negatively impact hydrologic systems. Together these results suggest that common loons may be sensitive to increases in temperature along their southern range boundary. Previous investigations of southern range determinants using either brood counts or bird presence did not detect similar patterns, which suggests that physiological measures may be more sensitive indicators of range contractions than more traditional bioclimatic envelope or demographic approaches.

## BIBLIOGRAPHY

- Alonso-Alvarez, C., and M. Ferrer. 2001. A biochemical study of fasting, subfeeding, and recovery processes in yellow-legged gulls. *Physiological and biochemical zoology* 74:703–13.
- Alvo, R., D. Hussell, and M. Berrill. 1988. The breeding success of common loons (*Gavia immer*) in relation to alkalinity and other lake characteristics in Ontario. *Canadian Journal of Zoology* 66:746–752.
- Armstrong, R. L., and M. J. Brodzik. 2006. Northern Hemisphere Snow Extent Derived from Microwave and Optical Satellite Data. Pages 1–7. . Boulder, Colorado.
- Badzinski, S. S., and S. T. A. Timmermans. 2006. Factors influencing productivity of common loons (*Gavia immer*) breeding on circumneutral lakes in Nova Scotia, Canada. *Hydrobiologia* 567:215–226.
- Barbet-Massin, M., B. a Walther, W. Thuiller, C. Rahbek, and F. Jiguet. 2009. Potential impacts of climate change on the winter distribution of Afro-Palaeartic migrant passerines. *Biology letters* 5:248–51.
- Barnett, T. P., J. C. Adam, and D. P. Lettenmaier. 2005. Potential impacts of a warming climate on water availability in snow-dominated regions. *Nature* 438:303–9.
- Barr, J. F. 1973. Feeding biology of the Common Loon (*Gavia immer*) in oligotrophic lakes of the precambrian shield. . Univ. of Guelph, Ontario.
- Bauch, C., S. Kreutzer, and P. H. Becker. 2010. Breeding experience affects condition: blood metabolite levels over the course of incubation in a seabird. *Journal of comparative physiology. B, Biochemical, systemic, and environmental physiology* 180:835–45.
- Beale, C. M., J. J. Lennon, and A. Gimona. 2008. Opening the climate envelope reveals no macroscale associations with climate in European birds. *Proceedings of the National Academy of Sciences of the United States of America* 105:14908–12.
- Blair, R. B. 1992. Lake Features, Water Quality and the Summer Distribution of Common Loons in New Hampshire. *Distribution* 63:1–9.
- Blenckner, T. 2005. A conceptual model of climate-related effects on lake ecosystems. *Hydrobiologia* 533:1–14.
- Breiman, L. 2001. Random Forests. *Machine Learning* 45:5–32.
- Breiman, L., J. Friedman, C. J. Stone, and R. A. Olshen. 1984. Classification and Regression Trees. . Chapman & Hall/CRC.

- Brown, J. L., S. H. Li, and N. Bhagabati. 1999. Long-term trend toward earlier breeding in an American bird: a response to global warming? *Proceedings of the National Academy of Sciences of the United States of America* 96:5565–69.
- Byrd, A. J., B. J. Olsen, D. C. Evers, and R. L. Holberton. 2012. Common Loon (*Gavia immer*) Biogeography & Reproductive Success in an Era of Climate Change.
- Carey, C. 1996. Avian Energetics and Nutritional Ecology. Pages 324–374. . Chapman & Hall/CRC, New York, New York, USA.
- Chase, M. K., N. Nur, and G. R. Geupel. 2005. Effects of Weather and Population Density on Reproductive Success and Population Dynamics in a Song Sparrow (*Melospiza melodia*) Population : A Long-Term Study. *The Auk* 122:571–592.
- Claudia Rauter, and H. Reyer. 2000. Thermal and energetic consequences of nest location and breeding times in Water Pipits (*Anthus spinoletta*). *Journal of Ornithology* 141:391–407.
- Corney, P. M., M. G. Le Duc, S. M. Smart, K. J. Kirby, R. G. H. Bunce, and R. H. Marrs. 2006. Relationships between the species composition of forest field-layer vegetation and environmental drivers, assessed using a national scale survey. *Journal of Ecology* 94:383–401.
- Crawley, M. 2007. *The R Book*. . Wiley, Chichester, England; Hoboken, N.J.
- Cutler, D. R., T. C. Edwards, K. H. Beard, A. Cutler, K. T. Hess, J. Gibson, and J. J. Lawler. 2007. Random forests for classification in ecology. *Ecology* 88:2783–92.
- Dale, V. 1997. The Relationship Between Land-Use Change and Climate Change. *Ecological Applications* 7:753–769.
- Davis, A. J., L. S. Jenkinson, J. H. Lawton, B. Shorrocks, and S. Wood. 1998a. Making mistakes when predicting shifts in species range in response to global warming. *Nature* 391:783–786.
- Davis, A. J., J. H. Lawton, B. Shorrocks, and L. S. Jenkinson. 1998b. Individualistic species responses invalidate simple physiological models of community dynamics under global environmental change. *Journal of Animal Ecology* 67:600–612.
- Deerenberg, C., I. Pen, C. Dijkstra, B.-J. Arkies, G. H. Visser, and S. Daan. 1995. Parental energy expenditure in relation to manipulated brood size in the european kestrel. *Zoology, Analysis of Complex Systems (ZACS)* 99:38–47.
- Desorbo, C. R., K. M. Taylor, D. E. Kramar, J. Fair, J. H. Cooley, D. C. Evers, W. Hanson, H. S. Vogel, and J. L. Atwood. 2007. Reproductive Advantages for Common Loons Using Rafts. *Journal of Wildlife Management* 71:1206–1213.



- De'ath, G., and K. Fabricius. 2000. Classification and regression trees: a powerful yet simple technique for ecological data analysis. *Ecology* 81:3178–3192.
- Doligez, B., E. Danchin, J. Clobert, and L. Gustafsson. 1999. The use of conspecific reproductive success for breeding habitat selection in a non-colonial, hole-nesting species, the collared flycatcher. *Journal of Animal Ecology* 68:1193–1206.
- Drilling, N. E., and C. F. Thompson. 1988. Natal and breeding dispersal in house wrens (troglodytes-aedon). *Auk* 105:480–491.
- Driscoll, C. T., K. M. Driscoll, K. M. Roy, and M. J. Mitchell. 2003. Chemical response of lakes in the Adirondack Region of New York to declines in acidic deposition. *Environmental science & technology* 37:2036–42.
- Dyke, A. S., and V. K. Prest. 1987. Late Wisconsinan and Holocene History of the Laurentide Ice Sheet. *Geographie physique et Quaternaire* 41:2.
- Enstipp, M. R., D. R. Jones, S.-H. Lorentsen, and D. Grémillet. 2007. Energetic costs of diving and prey-capture capabilities in cormorants and shags (Phalacrocoracidae) underline their unique adaptation to the aquatic environment. *Journal of Ornithology* 148:593–600.
- Eppley, Z. A. 1996. Society for Experimental Biology Seminar Series 59. Pages 313–346 *Development of Thermoregulation in Birds: physiology, interspecific variation and adaptation to climate.*
- Evers, D. C. 1992. A replicable capture method for adult and juvenile common loons on their nesting lakes. *Proc. From the 1992 conference on the loon and its ecosystem: Status, management, and environmental concerns.*:214–220.
- Evers, D. C. 2001a. *Common Loon Population Studies: Continental Mercury Patterns and Breeding Territory Philopatry.* . Univ. of MN, St. Paul, MN.
- Evers, D. C. 2001b. *Common Loon Population Studies: Continental Mercury Patterns and Breeding Territory Philopatry.*
- Evers, D. C., J. D. Paruk, J. W. McIntyre, and J. F. Barr. 2010. *Common Loon (Gavia immer).*
- Evers, D. C., L. J. Savoy, C. R. DeSorbo, D. E. Yates, W. Hanson, K. M. Taylor, L. S. Siegel, J. H. Cooley, M. S. Bank, A. Major, K. Munney, B. F. Mower, H. S. Vogel, N. Schoch, M. Pokras, M. W. Goodale, and J. Fair. 2008. Adverse effects from environmental mercury loads on breeding common loons. *Ecotoxicology (London, England)* 17:69–81.

- Ewert, D. 1982. Spring migration of Common Loons at Whitefish Point, Michigan. *Jack-Pine Warbler* 60:134–143.
- Ficke, A. D., C. a. Myrick, and L. J. Hansen. 2007. Potential impacts of global climate change on freshwater fisheries. Pages 581–613 *Reviews in Fish Biology and Fisheries*.
- Gaston, K. J. 2003. *The structure and dynamics of geographic ranges*. Oxford University Press.
- Gingras, B., and C. a. Paszkowski. 2006. Feeding behavior and modeled energetic intake of common loon (*Gavia immer*) adults and chicks on small lakes with and without fish. *Hydrobiologia* 567:247–261.
- Gostomski, T. J., and D. C. Evers. 1998. Time-activity budget for Common Loons, *Gavia immer*, nesting on Lake Superior. *Canadian Field-Naturalist* 112:191–197.
- Grear, J. S., M. W. Meyer, J. H. Cooley, A. Kuhn, H. Walter, M. G. Mitro, H. S. Vogel, K. M. Taylor, K. P. Kenow, S. M. Craig, D. E. Nacci, A. Press, and S. Grear. 2009. Population Growth and Demography the Northern United States of Common Loons in. *The Journal of Wildlife Management* 73:1108–1115.
- Greenwood, P. J., and P. H. Harvey. 1982. The natal and breeding dispersal of birds. *Annual Review of Ecology and Systematics* 13:1–21.
- Guglielmo, C. G., D. J. Cerasale, and C. Eldermire. 2005. A field validation of plasma metabolite profiling to assess refueling performance of migratory birds. *Physiological and biochemical zoology* 78:116–25.
- Hampe, A. 2004. Bioclimate envelope models : what they detect and what they hide. *Global Ecology & Biogeography* 13:469–476.
- Heikkinen, R. K., M. Luoto, M. B. Araujo, R. Virkkala, W. Thuiller, and M. T. Sykes. 2006. Methods and uncertainties in bioclimatic envelope modelling under climate change. *Progress in Physical Geography* 30:751–777.
- Hemberger, M., D. Euler, and J. Barr. 1983. The impact of cottage development on common loon reproductive success in central Ontario. *Wilson Bulletin* 95:431–439.
- Herlihy, A. T., J. L. Stoddard, and C. B. Johnson. 1998. The relationship between stream chemistry and watershed land cover data in the mid-atlantic region, U.S. *Water, Air, and Soil Pollution* 105:377–386.
- Hijmans, R. J., and C. H. Graham. 2006. The ability of climate envelope models to predict the effect of climate change on species distributions. *Global Change Biology* 12:2272–2281.

- Hitch, A. T., and P. L. Leberg. 2007. Breeding distributions of north American bird species moving north as a result of climate change. *Conservation biology : the journal of the Society for Conservation Biology* 21:534–9.
- Hodkinson, I. D. 1999. Species response to global environmental change or why ecophysiological models are important: a reply to Davis et al. *Journal of Animal Ecology* 68:1259–1262.
- Holberton, R. L. 2008. *Materials and basic methods for field blood collection, storage, etc.* . Orono, ME.
- Holt, R. D., and T. H. Keitt. 2005. Species ' borders : a unifying theme in ecology. *Oikos* 108:3–6.
- Holt, R. D., T. H. Keitt, M. A. Lewis, B. A. Maurer, and M. L. Taper. 2005. Theoretical models of species ' borders : single species approaches. *Oikos* 108:18–27.
- IPCC. 2007. Contribution of Working Group I to the Fourth Assessment Report of the Intergovernmental Panel on Climate Change. Page 996 (S. D. Solomon, M. Qin, M. Manning, Z. Chen, M. Marquiz, K. B. Averyt, M. Tignor, and H. L. Miller, Eds.). . Cambridge University Press, United Kingdom and New York.
- Jacobson, G. L., I. J. Fernandez, P. A. Mayewski, and C. V. Schmitt. 2009. *Maine's Climate Future: An Initial Assessment.* . Orono.
- Jenni, L., and R. Schilch. 2001. Plasma metabolite levels indicate change in body mass in reed warblers *Acrocephalus scirpaceus*. *Avian Science* 1:55–65.
- Jenni-Eiermann, S., and L. Jenni. 1994. Plasma Metabolite Levels Predict Individual Body-Mass Changes in a Small Long-Distance Migrant , the Garden Warbler Author. *The Auk* 111:888–899.
- Jenni-Eiermann, S., and L. Jenni. 1997. Diurnal Variation of Metabolic Responses to Short-Term Fasting in Passerine Birds during the Postbreeding , Molting and Migratory Period. *The Condor* 99:113–122.
- Jenni-Eiermann, S., and L. Jenni. 1998. What can plasma metabolites tell us about the metabolism, physiological state and condition of individual birds? An overview. *Biological Conservation Fauna* 102:312–319.
- Jenssen, B. M., M. Ekker, and C. Bech. 1988. Thermoregulation in winter-acclimatized common eiders (*Somateria mollissima*) in air and water. *Canadian Journal of Zoology* 67:669–673.

- Jodice, P. G. R., D. D. Roby, R. M. Suryan, D. B. Irons, K. R. Turco, E. D. Brown, J. F. Thedinga, and G. H. Visser. 2006. Increased energy expenditure by a seabird in response to higher food abundance. *Marine Ecology Progress Series* 306:283–293.
- Jose Pinheiro, D. Bates, S. DebRoy, and D. Sarkar. 2011. nlme: Linear and Nonlinear Mixed Effects Models. R package version 3.1-106.
- Karasov, W. H., K. P. Kenow, M. W. Meyer, and F. Fournier. 2007. Bioenergetic and pharmacokinetic model for exposure of common loon (*Gavia immer*) chicks to methylmercury. *Environmental toxicology and chemistry / SETAC* 26:677–85.
- Kaushal, S. S., P. M. Groffman, G. E. Likens, K. T. Belt, W. P. Stack, V. R. Kelly, L. E. Band, and G. T. Fisher. 2005. Increased salinization of fresh water in the northeastern United States. *Proceedings of the National Academy of Sciences of the United States of America* 102:13517–20.
- Keating, J. 2004. Deicing Salt: Still on the Table. Stormwater.
- Kenow, K. P. K., D. A. Dams, N. Schoch, D. Evers, W. Hanson, D. Yates, L. Savoy, T. Fox, A. Major, R. Kratt, J. Ozard, R. O. K. Ratt, and J. O. H. N. O. Zard. 2009. Migration Patterns and Wintering Range of Common Loons Breeding in the Northeastern United States. *Waterbirds* 32:234–247.
- Kenow, K. P., M. W. Myer, R. K. Hines, and W. I. H. K. Karasov. 2007. Distribution and accumulation of mercury in tissues of captive-reared common loon (*Gavia immer*) chicks. *Environmental toxicology and chemistry / SETAC* 26:1047–1055.
- Kingston, J. D., A. L. Deino, R. K. Edgar, and A. Hill. 2007. Astronomically forced climate change in the Kenyan Rift Valley. *Journal of Human Evolution* 53:487–503.
- Kuhn, A., J. Copeland, J. Cooley, H. Vogel, K. Taylor, D. Nacci, and P. August. 2011. Modeling Habitat Associations for the Common Loon (*Gavia immer*) at Multiple Scales in Northeastern North America. *Avian Conservation and Ecology* 6.
- Lathrop, R. C., S. R. Carpenter, and D. M. Robertson. 1999. water clarity responses to phosphorus, *Daphnia* grazing, and internal in Lake Mendota mixing. *Limnology and Oceanography* 44:137–146.
- Laudon, H., P. J. Dillon, M. C. Eimers, R. G. Semkin, and D. S. Jeffries. 2004. Climate-induced episodic acidification of streams in central ontario. *Environmental science & technology* 38:6009–15.
- Liaw, A., and M. Wiener. 2012. Package “randomForest”. . CRAN.

- Lozano, G. A., and R. E. Lemon. 1998. Parental-care responses by yellow warblers (*Dendroica petechia*) to simultaneous manipulations of food abundance and brood size. *Canadian Journal of Zoology* 76:916–924.
- Mager, J. N., and C. Walcott. 2007. Structural and contextual characteristics of territorial “yodels” given by male Common Loons (*Gavia immer*) in northern Wisconsin. *Passenger Pigeon* 69:327–337.
- Mager, J. N., C. Walcott, and W. H. Piper. 2007. Male Common Loons, *Gavia immer*, communicate body mass and condition through dominant frequencies of territorial yodels. *Animal behaviour* 73:683–690.
- Magnuson, J. J., K. E. Webster, R. A. Assel, C. J. Bowser, P. J. Dillon, J. G. Eaton, H. E. Evans, E. J. Fee, R. I. Hall, L. R. Mortsch, D. W. Schindler, and F. H. Quinn. 1997. Potential effects of climate changes on aquatic systems : laurentian great lakes and precambrian shield region. *Hydrological Processes* 11:825–871.
- Martinez-Morales, M. A., I. Zuria, L. Chapa-Vargas, I. MacGregor-Fors, R. Ortega-Alvarez, E. Romero-Aguila, and P. Carbo. 2010. Current distribution and predicted geographic expansion of the Rufous-backed Robin in Mexico: a fading endemism? *Diversity and Distributions* 16:786–797.
- Martins, T., and W. J. 1993. Cost of reproduction and allocation of food between parent and young in the swift (*Apus apus*). *Behavioral Ecology* 4:213±223.
- Matthews, S. N. 2004. Atlas of climate change effects in 150 bird species of the Eastern United States. . US Department of Agriculture, Forest Service, Northeastern Research Station.
- McIntyre, J. W. 1994. Loons in freshwater lakes. *Hydrobiologia* 279-280:393–413.
- McIntyre, J. W. ., and J. F. . Barr. 1983. Pre-Migratory Behavior of Common Loons on the Autumn Staging Grounds. *Wilson Ornithological Society* 95:121–125.
- McNicol, D. K., M. L. Mallory, and H. S. Vogel. 1995. Using volunteers to monitor the effects of acid precipitation on common loon (*Gavia immer*) reproduction in canada: the canadian lakes loon survey. *Water, Air, and Soil Pollution* 85:463–468.
- Moreno, J. 1989. Strategies of mass change in breeding birds. *Biological Journal of the Linnean Society*:297–310.
- Nagy, K. a, I. a Girard, and T. K. Brown. 1999. Energetics of free-ranging mammals, reptiles, and birds. *Annual review of nutrition* 19:247–77.

- Newman, S. H., J. F. Piatt, and J. White. 1997. Hematological and Plasma Biochemical Reference Ranges of Alaskan Seabirds : Their Ecological Significance and Clinical Importance. *Colonial Waterbirds* 20:492–504.
- Nickerson, D. M., D. E. Facey, and G. D. Grossman. 1988. Estimating Physiological Thresholds with Continuous Two-Phase Regression. *Physiological Zoology* 62:866–887.
- Nocera, J. J., and N. M. Burgess. 2002. Diving schedules of Common Loons in varying environments. *Canadian Journal of Zoology* 80:1643–1648.
- Olson, S. T., and W. H. Marshall. 1952. The Common Loon in Minnesota.
- O'Connor, R. J., and T. L. Wagner. 2004. a Test of a Regression-Tree Model of Species Distribution. *The Auk* 121:604.
- Parker, K. E. 1988. Common Loon Reproduction and Chick Feeding on Acidified Lakes in the Adirondack Park, New York. *Canadian Journal of Zoology* 66:804–810.
- Paruk, J. D. 2009. Function of the common loon foot waggle. *The Wilson Journal of Ornithology* 121:392–398.
- Payne, R. B., and L. L. Payne. 1993. Breeding dispersal in Indigo Buntings: circumstances and consequences for breeding success and population structure. *Condor* 95:1–24.
- Pearson, R. G., and T. P. Dawson. 2003. Predicting the impacts of climate change on the distribution of species : are bioclimate envelope models useful ? *Global Ecology & Biogeography* 12:361–371.
- Peeters, F., D. Straile, A. Lorke, and D. Ollinger. 2007. Turbulent mixing and phytoplankton spring bloom development in a deep lake. *Limnology and Oceanography* 52:286–298.
- Pettifor, R. A. 1993. Brood-manipulation experiments II. A cost of reproduction in blue tits (*Parus caeruleus*)? *Journal of Animal Ecology* 62:145–159.
- Pinheiro, J. C., and D. M. Bates. 2000. *Mixed-effects models in S and S-PLUS*. . New York: Springer.
- Piper, W. H., D. Evers, M. W. Meyer, K. B. Tischler, D. Kaplan, and R. C. Fleischer. 1997a. Genetic monogamy in the common loon (*Gavia immer*). *Behavioral Ecology and Sociobiology* 41:25–31.

- Piper, W. H., J. D. Paruk, D. C. Evers, M. W. Meyer, B. Keren, M. Klich, and J. J. Hartigan. 1997b. Local Movements of Color-Marked Common Loons. *The Journal of Wildlife Management* 61:1253–1261.
- Piper, W. H., C. Walcott, J. N. Mager, and F. J. Spilker. 2008a. Nestsite selection by male loons leads to sex-biased site familiarity. *Journal of Animal Ecology* 77:205–210.
- Piper, W. H., C. Walcott, J. N. Mager, and F. J. Spilker. 2008b. Fatal battles in common loons: a preliminary analysis. *Animal Behaviour* 75:1109–1115.
- Piper, W., K. Tischler, and M. Klich. 2000. Territory acquisition in loons: the importance of take-over. *Animal behaviour* 59:385–394.
- Poff, N. L. 2002. Ecological response to and management of increased flooding caused by climate change. *Philosophical transactions. Series A, Mathematical, physical, and engineering sciences* 360:1497–510.
- Pokras, M. A., C. Hanley, and Z. Gordon. 1998. Liver mercury and methylmercury concentrations in New England common loons (*Gavia immer*). *Environmental Toxicology and Chemistry* 17:202–204.
- Price, E. R., A. Krokfors, and C. G. Guglielmo. 2008. Selective mobilization of fatty acids from adipose tissue in migratory birds. *The Journal of experimental biology* 211:29–34.
- Pörtner, H. O. 2002. Climate variations and the physiological basis of temperature dependent biogeography: systemic to molecular hierarchy of thermal tolerance in animals. *Comparative biochemistry and physiology. Part A, Molecular & integrative physiology* 132:739–61.
- Quillfeldt, P., J. F. Masello, and E. Mostl. 2004. Blood chemistry in relation to nutrition and ectoparasite load in Wilson's storm-petrels *Oceanites oceanicus*. *Polar Biology* 27:168–176.
- Ramakrishna, D. M., and T. Viraraghavan. 2005. Environmental Impact of Chemical Deicers – A Review. *Water, Air, and Soil Pollution* 166:49–63.
- Robinson, D. A., and R. R. Heim Jr. 2006. Trends and variability of snowfall and snow cover across north america and eurasia. Part 2: what the data say. Pages 1–5. . Asheville, NC.
- Rodenhouse, N. L., S. N. Matthews, K. P. McFarland, J. D. Lambert, L. R. Iverson, a. Prasad, T. S. Sillett, and R. T. Holmes. 2007. Potential effects of climate change on birds of the Northeast. *Mitigation and Adaptation Strategies for Global Change* 13:517–540.

- Rosenberry, D. O., P. A. Bukaveckas, D. C. Buso, G. E. Likens, A. M. Shapiro, and T. C. Winter. 1999. MOVEMENT OF ROAD SALT TO A SMALL NEW HAMPSHIRE LAKE. *Water, Air, and Soil Pollution* 109:179–206.
- Rowley, I. 1983. Re-mating in birds. Pages 331–360 (P. Bateson, Ed.) *Hydrobiologia*. Cambridge University Press.
- Ruggles, A. K. 1994. Habitat selection by loons in southcentral Alaska. *Hydrobiologia* 279-280:421–430.
- Seavy, N. E., K. E. Dybala, and M. a. Snyder. 2008. Climate Models and Ornithology. *The Auk* 125:1–10.
- Sedgwick, J. A. 2004. Site fidelity, territory fidelity and natal philopatry in willow flycatchers (*Empidonax traillii*). *Auk* 121:1103–1121.
- Senar, J. C., and J. Pascual. 1997. Keel and Tarsus Length May Provide A Good Predictor of Avian Body Size. *Ardea* 85:269–274.
- Sidor, I. F., M. a Pokras, A. R. Major, R. H. Poppenga, K. M. Taylor, and R. M. Miconi. 2003. Mortality of common loons in New England, 1987 to 2000. *Journal of wildlife diseases* 39:306–15.
- Sonzogni, W. C., W. Richardson, P. Rodgers, and T. J. Monteith. 1983. Chloride pollution of the Great Lakes. *Journal of Water Pollution* 55:513–521.
- Stamps, J. A. 1987. Conspecifics as Cues to Territory Quality- A Preference of Juvenile Lizards (*Anolis-Aeneus*) for Previously Used Territories. *American Naturalist* 129:629–642.
- Stanley, T., and J. A. Royle. 2005. Estimating site occupancy and abundance using indirect detection indices. *Journal of Wildlife Management* 69:3.
- Switzer, P. V. 1997. Past reproductive success affects future habitat selection. *Behavioral Ecology and Sociobiology* 40:307–312.
- Therneau, T., B. Atkinson, and B. Ripley. 2012. Package “rpart.”
- Thomas, C. D., E. J. Bodsworth, R. J. Wilson, a D. Simmons, Z. G. Davies, M. Musche, and L. Conradt. 2001. Ecological and evolutionary processes at expanding range margins. *Nature* 411:577–81.
- Thomas, C. D., A. Cameron, R. E. Green, M. Bakkenes, L. J. Beaumont, Y. C. Collingham, B. F. N. Erasmus, M. F. De Siqueira, A. Grainger, L. Hannah, L. Hughes, B. Huntley, A. S. Van Jaarsveld, G. F. Midgley, L. Miles, M. a Ortega-



- Huerta, a T. Peterson, O. L. Phillips, and S. E. Williams. 2004. Extinction risk from climate change. *Nature* 427:145–8.
- Thomas, C. D., and J. J. Lennon. 1999. Birds extend their ranges northwards. *Nature* 399:6505.
- Thomson, D. L., P. Monaghan, and R. W. Furness. 1998. The demands of incubation and avian clutch size. *Biological Review* 73:293–304.
- Thuiller, W. 2003. BIOMOD - optimizing predictions of species distributions and projecting potential future shifts under global change. *Global Change Biology* 9:1353–1362.
- Totzke, U., M. Fenske, O. Hüppop, H. Raabe, and N. Schach. 1999. The influence of fasting on blood and plasma composition of herring gulls (*Larus argentatus*). *Physiological and biochemical zoology* 72:426–37.
- Vallecillo, S., L. Brotons, and W. Thuiller. 2009. Dangers of predicting bird species distributions in response to land-cover changes. *Ecological applications* : a publication of the Ecological Society of America 19:538–49.
- Venables, W. N., and B. D. Ripley. 2009. *Modern Applied Statistics with S*. Fourth Edition. . Springer, New York.
- Virkkala, R., R. K. Heikkinen, N. Leikola, and M. Luoto. 2008. Projected large-scale range reductions of northern-boreal land bird species due to climate change. *Biological Conservation* 141:1343–1353.
- Waite, T. a, and D. Strickland. 2006. Climate change and the demographic demise of a hoarding bird living on the edge. *Proceedings. Biological sciences / The Royal Society* 273:2809–13.
- Walsberg, G. E. 1983. *Avian Biology*. Pages 135–158.
- Walther, G., E. Post, P. Convey, A. Menzel, C. Parmesank, T. J. C. Beebee, J. Fromentin, O. H. I, and F. Bairlein. 2002. Ecological responses to recent climate change. *Nature* 416:389–395.
- Watkinson, A. R., J. a. Gill, and M. Hulme. 2004. Flying in the face of climate change: a review of climate change, past, present and future. *Ibis* 146:4–10.
- Weathers, W. W. 1979. Climatic adaptation in avian standard metabolic rate. *Oecologia* 42:81–89.
- Weathers, W. W. 1997. Energetics and thermoregulation by small passerines of the humid, lowland tropics. *Auk* 114:341–353.

- Weathers, W. W., and E. Greene. 1998. Thermoregulatory responses of bridled and juniper titmice to high temperature. *Condor* 100:365–372.
- Wetzel, R. 2005. *Limnology*. . Saunders, New York, New York, USA.
- Williams, J. B. 1996. Energetics of avian incubation. Pages 375–415 *Avian energetics and nutritional ecology*. . London: Chapman & Hall.
- Williams, J. W., and S. T. Jackson. 2012. Novel ecological climates , No-Analog Communities, and Ecological Surprises. *Frontiers in Ecology and the Environment* 5:475–482.
- Wolfe, A. P., J. S. Baron, and R. J. Cornett. 2001. Anthropogenic nitrogen deposition induces rapid ecological changes in alpine lakes of the Colorado Front Range ( USA ). *Journal of Paleolimnology* 25:1–7.
- Zuur, A. F., E. N. Ieno, N. J. Walker, A. A. Saveliev, and G. M. Smith. 2009. *Mixed effects models and extensions in ecology with R*. . New York: Springer.

## **BIOGRAPHY OF THE AUTHOR**

Allison Jeanne Byrd was born in Flemington, NJ on June 28<sup>th</sup>, 1979. She graduated from Voorhees High School in 1997. She attended The University of Rhode Island (Kingston, R.I.) and earned a B.S. in Wildlife Biology in 2001 after also completing course work at an overseas course at the University of Bath, England. Allie worked as a biological technician in the western United States (Washington, Wyoming, and Montana), on Santa Cruz Island (California), and in the eastern United States (North Carolina, Florida, New Jersey) studying birds and mammals. She also worked as a biological technician abroad in Australia, Mexico, and Panama studying birds. She is a candidate for the Master of Science degree in Ecology and Environmental Science from the University of Maine in May, 2013.