



THE MAINE FOLKLIFE CENTER

Celebrating Traditional Arts and Culture of Maine and the Region

Volume 16: Issue 1, Spring/Summer 2011

2011 AMERICAN FOLK FESTIVAL

Folk and Traditional Arts Area featuring Farms, Farm Stands, and Farmer's Markets

This year's folk and traditional arts area of the American Folk Festival focuses on the important role that Maine Farm traditions have played in the past, how farms are faring in the present, and how they will continue to provide food security to Maine people in the future.

With the aid of University of Maine Cooperative Extension we will focus our educational efforts on the ways that farmers are getting fresh nutritious food to people, especially those experiencing food insecurity.

We will also provide demonstrations of skills that home gardeners need such as

bee keeping, making a cold frame, creating compost. Also, we will discuss how to save money by making bread and pancake mixes, cheeses and how to make a meal from farmer's market produce.

We will talk to farmers about how they are meeting today's energy and climate change challenges, and we will talk to some of Maine's farmer poets and musicians about how their occupation shapes their artistic creations.

More on pg. 4-5

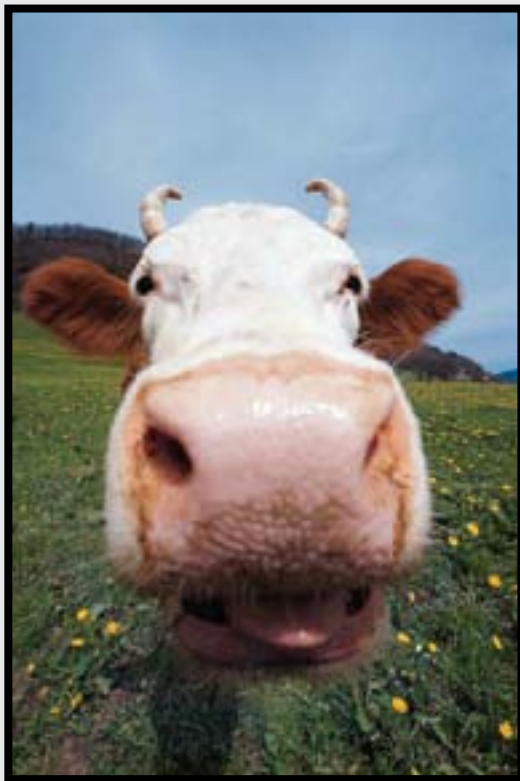
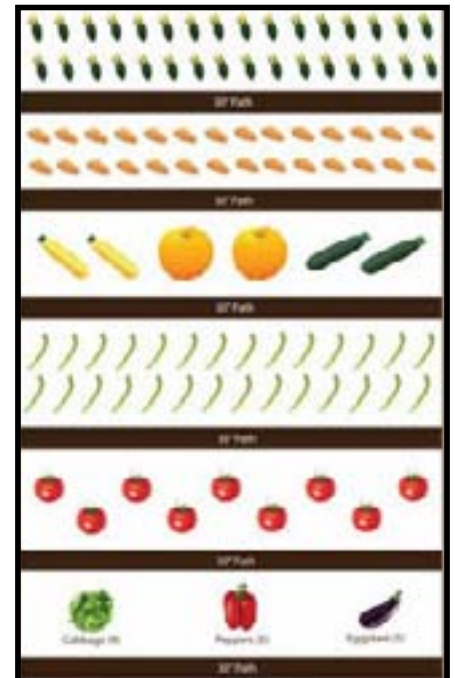

Photo credit: activerain.com

INSIDE:

2011 AMERICAN FOLK FESTIVAL:
AFF Folk and Traditional Arts Area event schedule
(page 4-5)

HAPPENINGS:
Second Annual Downeast Irish Review (page 3)

FORTHCOMING:
British Ballads from Maine (page 2)

UPDATE:
Maine Song and Story Sampler (page 2)

FOCUS ON THE STUDENT:
Walter Beckwith, Anthropology (page 3)

FROM THE ARCHIVES:
Story of the Split Tree (page 6)

British Ballads from Maine

B*ritish Ballads from Maine*, edited by Phillips Barry, Fannie Hardy Eckstorm and Mary Winslow Smyth was published by Yale University Press in 1929. It is an academic collection of Child ballads that the authors collected from singers in Maine. Each ballad is listed with Child numbers with variants used to illustrate the sources and dates of the collection. The authors hoped to demonstrate the richness of New England as a ballad area, to prove that many American ballad texts are old compared with those printed in the Child collection, and to provide a handbook for fieldworkers who might wish to collect additional ballads. The three authors spent several years collecting songs in eastern Maine and New Brunswick. There were a total of 94 texts with tunes transcribed by Indiana University professor George Herzog. The authors included fifty-six Child ballads were, eight secondary ballads and thirty traces and jury texts in the volume.

After completing this volume the three continued their fieldwork and analysis and began putting together a manuscript of additional ballads for a second volume. The volume was never published and languished for many years in Mrs. Barry's barn until after her death; the papers made their way to the Barry Collection in Harvard's Houghton Library. Some years later, Boston musician Jim Douglas collated and organized the volume and wrote an introduction, sending it to Sandy Ives to see if he would publish it. Ives was busy with other things and it did not get published. Eventually, hearing of my interest in Eckstorm's work, Douglas sent the whole thing to me. It has been sitting in my office for years. A few years ago, I digitized the whole manuscript and began copyediting it. I am currently preparing it for publication and plan to have it available to our members as the next volume of *Northeast Folklore* in 2012. Meanwhile, musician Fred Gosbee is preparing the music from George Herzog's transcriptions. The volume will include an introductory essay by Phillips Barry, never before published in which he redefines the popular ballad. In addition, there are 32 ballads, with numerous variations, all collected in Maine in the 1930s by Phillips Barry, Fannie Hardy Eckstorm and Mary Winslow Smyth.

- Pauleena MacDougall

Maine Song and Story Sampler update

Last year, the Maine Folklife Center received a grant from the National Endowment of the Arts to create the "Maine Song and Story Sampler," a project that would compile – and make available on the web - some of the best songs and stories from the region.

Spearheaded by graduate assistant Joshua Parda, the bulk of the work in the Fall of 2010 focused on songs. Many of these selections were previewed on the Folklife Center's facebook page and website. This Spring, Parda shifted his focus to researching stories, which soon will be available on our website.

So far, Parda has found that the Folklife Center has an abundance of stories that would suit the project. Included in the Northeast Archives of Folklore and Oral History are: tall tales, legends, fables, folk medicines, jokes, ghost stories, funny stories, sad or tragic stories, and oral histories. These various themes come from the diverse cultures of Maine, including the Swedish, Finnish, Native American, African American, Russian, Ukranian, Polish, as well as the larger group of white, English speaking Mainers.

The stories draw from work cultures that include coastal industries like boat building, fish packing, and lobstering, as well as the lumberwoods, basketmaking, farming, and many others. For example, Fred Macgowan of Ashland, Maine offered a story of Paul Bunyan breaking out of jail in New Brunswick.

Albert Collins of Blue Hill told one about how his father scared the life out of his boss while delivering mail by boat to the island communities. Thomas MacLeod of Baring told an old warning story about how a logger was a blasphemous and wound up eating break-

fast in Hell.

Alan Dixon of South Paris told the story of her grandfather, and how he was the first Finn to settle into the area, doing so by accident. Chester Ringdahl and other descendants of Swedish immigrants told similar stories of their ancestors. These common stories among different cultures showed the mixed feelings about moving to Maine.

When sufficient material has been collected, the sampler project will be available at the Maine Folklife Center webpage at <http://www.umaine.edu/folklife>. Previews can be seen on our Facebook Group. Just go to www.facebook.com and search Maine Folklife Center to find our group page. Look for updates on the launching of the official Song and Story Sampler website in September.



Second Annual Downeast Irish Review

On March 11, the Maine Folklife Center hosted The Press Gang, a young and energetic band from Portland Maine including squeezebox player Christian "Junior" Stevens, fiddler Alden Robinson, and guitarist Owen Marshall. The trio played a variety of traditional Irish tunes and a few non-traditional tunes to the enjoyment of an enthusiastic audience at the Penobscot theater in Bangor. Graduate student and thespian David St. Pierre read Irish Folktales and the local dance troupe, the Shamrock dancers demonstrated a reel, slip jig and the traditional set dance: St. Patrick's Day. The Folklife center established The Downeast Irish Revue as a way to celebrate the traditions brought to Maine by Irish immigrants. The program was held at Bangor's Penobscot Theater to help ring in a week of St. Patrick's Day cultural activities in our area.



The Press Gang

FOCUS ON THE STUDENT

Walter Beckwith

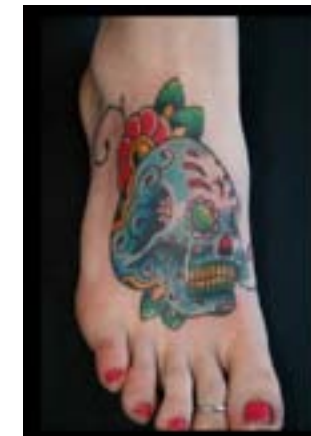
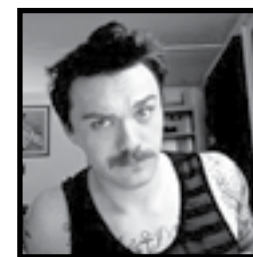

Photo credit: Made Rite Tattoos

In addition to completing his undergraduate studies, Walter Beckwith has been named the Outstanding Graduating Senior in Anthropology. His capstone project titled "Pure Vida: The Traditional American Tattoo," was accepted for presentation at the 2011 CUGR Conference (Center for Undergraduate Research).

Beckwith's project focused on Americana style tattoos, easily recognized by their use of bold color and silhouettes. Traditionally, this style had maritime themes, and was popular with sailors. Beckwith's research focused on the folklore and symbolism of this style, and of tattoos in general. A folk myth that Beckwith shares is of a tattoo of a wooden barrel that sailors would get on their feet. This tattoo would ensure that if a ship was lost at sea, the sailors body would be found because it would float, like a barrel, to shore.

Beckwith's research began with an internship with Made Rite Tattoo in Portland, Maine, where he worked closely with John Biswell, well known for his work with the Americana style. He combined his hands-on experience with Biswell with the guidance of folklore professor Karen Miller, who advised him on his Capstone project.

Beckwith will be starting his Graduate studies this fall at UMaine with the Climate Change Institute.

The 2011 American Folk Festival's Folk and Traditional Arts Area

Farms, Farm Stands and Farmer's Markets

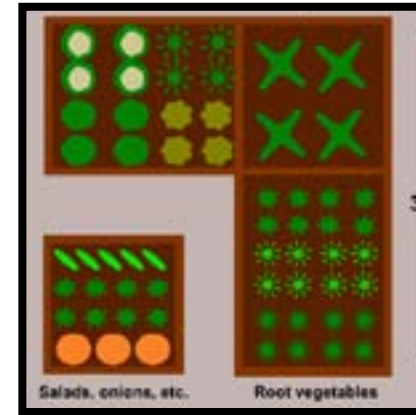

Narrative Stage Schedule

SATURDAY:

12-1pm Meet Your Maine Farmers

Facilitator: Gary Anderson, UMaine Extension. Panelists: Barbara Brooks, Seal Cove Farm; Jason Kafka, Checkerberry Farm; Henry Perkins, Bullridge Farm

1-2 Food Preservation

Jason Bolton, UMaine Extension

2-3 Growing Herbs

Heather Gordon, Master Gardener

3-4 Beekeeping Dos and Dont's

Carol Cottrill

4-5 Maine Farmer Poets

Facilitator: Judy Hakola.

Panelists: Sid and Sunny Stutzman, Patricia Ranzoni, and Russell Libby

SUNDAY:

12-1 Maine Farmer Poets

Facilitator: Judy Hakola.

Panelists: Sid and Sunny Stutzman, Patricia Ranzoni, and Russell Libby

1-2 How to Make Cheese

Scott Belanger, Olde Oak Farms

2-3 How to Make Master Mixes

Susan Henner, UMaine Extension

3-4 Farmer's Market Cooking Competition

Facilitator: Deb Averill

4-5 Tasting and Judging

Demonstration Tent

EXHIBITS:

Page Farm and Home Museum; "Tools of the Trade" will exhibit a cheese cabinet, honey extractor and other agricultural artifacts from their collection.

Hudson Museum; "Thanks to the Plants" exhibit will feature Native creative expressions that represent agricultural items: beaded floral designs, corn and pumpkin baskets, etc.

University of Maine Cooperative Extension; "Growing Vegetables in Containers." Raising vegetables in containers is a way to overcome impediments to gardening. With careful attention to the type of container, soil, site, plants per container and variety you too can have a successful mini-garden on your deck or front step.

DEMONSTRATIONS:

Potato Basket Making, with Donna Sanipass from Presque Isle Gardening with Herbs. Come learn some of the basics of herb gardening; what to grow, when to harvest, and how to use them in the kitchen, in the medicine closet, and around the house.

Gardening in a Raised Bed. Learn how to build a raised bed with special features to help extend the growing season. A raised bed will be constructed and the following topics will be discussed: crop selection, drip irrigation, and strategies for managing temperature during the early and late parts of the traditional growing season

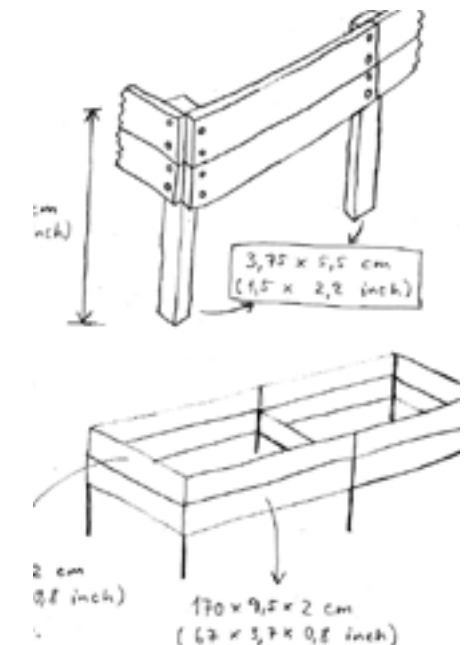

FROM THE ARCHIVES

This is a tale about Jones Tracy, a tall tale teller from MDI. This is one version of a story recounted by many residents of the island who heard it from Tracy directly, or indirectly from other sources who attributed the story to Tracy. This is the story of "Riding the Spar" as told by Lindsey

"He was coming from up the head of the Sound down to Northeast Harbor and taking the short cut over Brown's Mountain dressed in his party clothes including a claw-hammer coat, and he felt that he was getting a little behind time to get to the party on time and he happened to see a log laying on the Mountain. It was quite steep, and he conceived the idea of starting it sliding and jumping on, which he did. And it went faster and faster and he had no control over it. Pretty soon there was a big pine tree loomed up ahead of him, right dead ahead. Well, he couldn't, he didn't dare jump off and he just let her go and it hit that pine tree and split it wide open and snapped to behind him and took the tails right off his coat!"



This story was published as part of Lunt, C. Richard K. "Jones Tracy: Tall Tale Teller from Mount Desert Island," Northeast Folklore, X (1968).

Thank you to our New Members!

Richard Engels
Bill Lippincott
Patricia A. Troicke
Donald Collins

Jean Duncan
David Slagger
Robert Tymocko

Folklife Center Gets New Volunteer Librarian

The Maine Folklife Center operates off a small, but dedicated staff of a few federal work-study students, and grant funded research assistants. In this challenging economic climate, we are grateful to have a new volunteer, Barbara Stephens, a retired librarian.

Most recently, Stephens worked in Special Collections at Fogler Library. Prior to coming to Maine, she had a variety of library assignments, from Kansas to the Harlem Public Library, where she worked during the Civil Rights movement.

Stephens has been a librarian since she was a girl. As the story goes, it all started back when she lived in the York Center Co-Op, an experimental living community:

I remember as a young teenager making weekly trips to the library in the pump house to check out the new supply of reading material. Eventually I was allowed to play librarian and check books out to other people. And then I decided I would make a card catalog for all the books in the library. I got a supply of 3 x 5 cards and a typewriter and started cataloging all the books in the adult fiction section. After a few days of this work and having

gone through the authors whose last name began with A and B, I realized that no one would probably use this card catalogue, so I stopped. And what am I doing now every day of the work week almost 40 years later? I am cataloging books. Only this time I am entering the cataloging information into a computerized database the can be searched by people all over the world. I think I have the distinction of being the only person who discovered her professional career in the Co-op pump house.

The project that stopped in the pump house has been, in a way, picked back up at the Folklife Center. The adult fiction section of the Co-op has been replaced by the folklore and oral histories of Maine and the Maritimes. Instead of hand-writing card catalogues, she has helped us archive new collections, improve our existing archive of close to 4,000 accessions, as well as provide mentorship in library science to the rest of the 2010-2011 staff, which included Terri Bastarache, Christina Ramsdell, Dennis St. Pierre, Joushua Parda, Jason Canniff, and Bethany Haverlock.



Drive Dull Care Away Campaign Update

Our campaign to raise one million dollars continues making steady progress. In December we received 17 gifts totaling \$6,125.00 and one pledge of \$1,000. In January we received 11 gifts totaling \$1775.00. We are seeking additional hosts for other areas of Maine, especially central, southern and western Maine. If you would like to know more about the house party process, please contact Pauleena MacDougall.

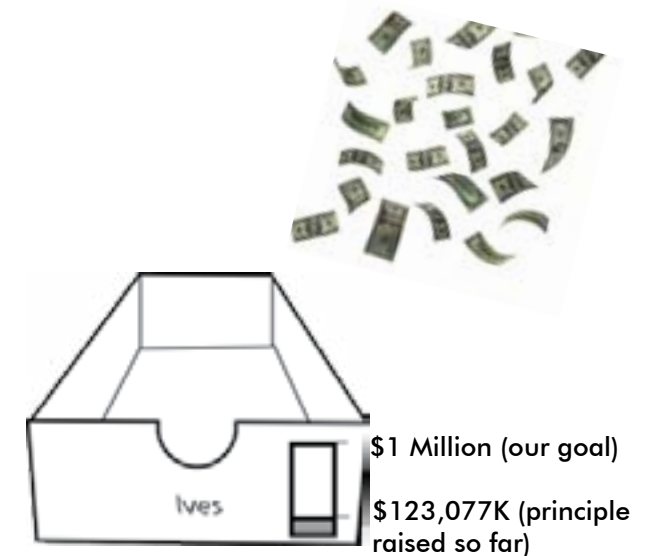



THE MAINE
FOLKLIFE
CENTER

5773 South Stevens Hall
University of Maine
Orono, ME 04469
Email: Folklife@maine.edu
www.umaine.edu/folklife/
Editor: Pauleena MacDougall
Editor/designer: Jason Canniff

Non-Profit Organization
U.S. Postage
PAID
Orono, ME 04469
Permit No. 8

PLEASE JOIN US!

Membership dues and contributions enable the Maine Folklife Center to function as a self-supporting unit of the University of Maine. By pledging membership, individuals and institutions play a vital role in encouraging the study, documentation and presentation of Maine's traditional cultural heritage.

Benefits of membership include:

- A copy of our annual Northeast Folklore publication
- The Maine Folklife Center newsletter
- A 10% discount on audio, video and publications

Please circle your desired membership level:

\$10,000 Sandy Ives Founders' Circle
\$5,000 Prince Edward Islander
\$1,000 Mainer

\$500 Song Catcher
\$250 Storyteller
\$100 Folk Artist

\$50 River Driver
\$25 Basic Membership
_____ Other Donation

Any contribution greater than a \$25 basic membership is considered a gift. Please make checks or money orders payable to the University of Maine. Your contributions are tax-deductible to the extent allowed by law.

Name: _____
Address: _____
